

# 智慧工業物聯網方案

自動化工業控制

Jason Tu 涂結盛



Where the “SMART” is,  
Where the “SENSOR” is.

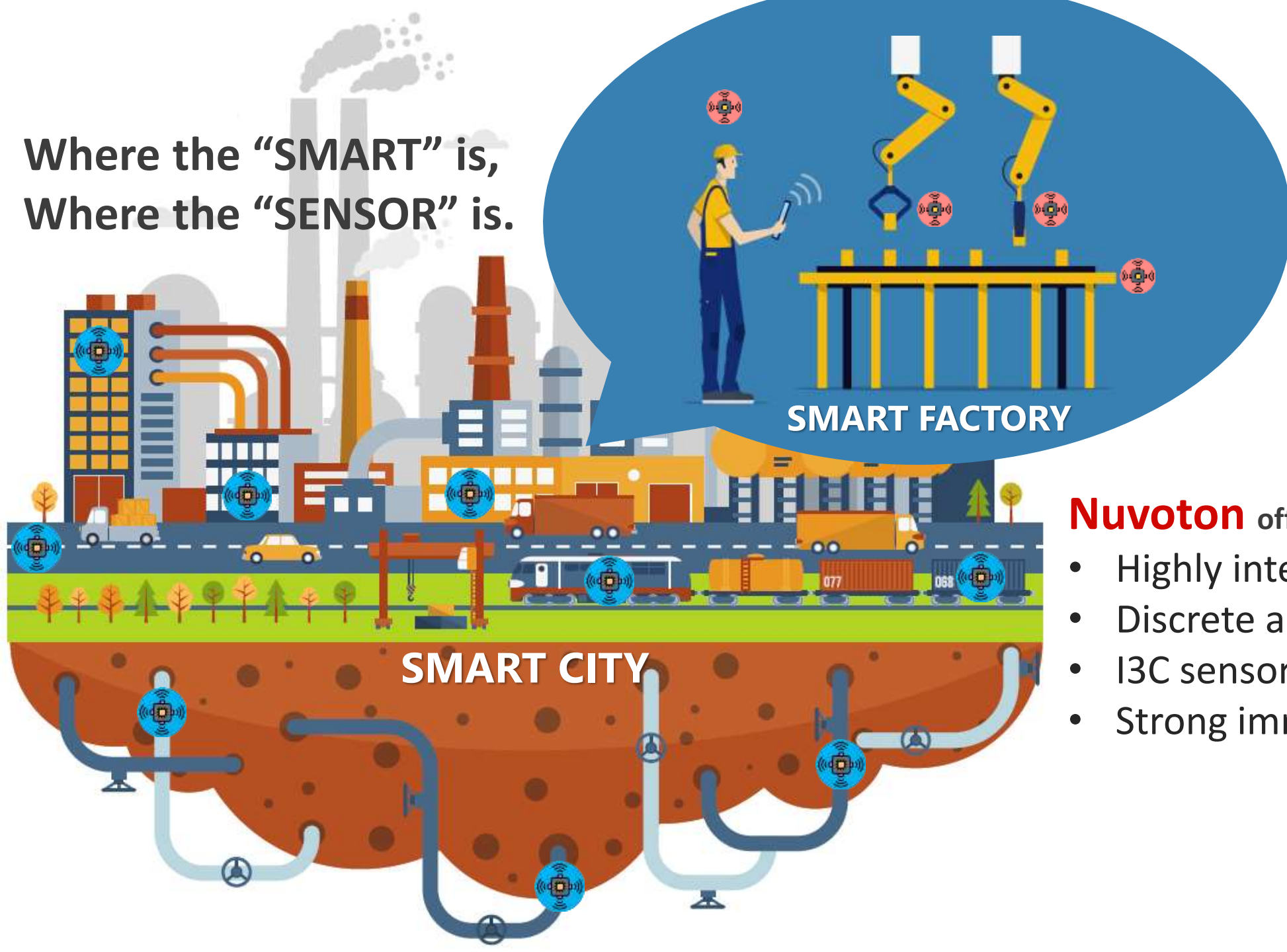

**Nuvoton** offers you

- Highly integrated analog **M091**
- Discrete analog **NADC24, NOP**
- I3C sensor hub **NUC1263**
- Strong immunity value up **MG51**

**NuMicro<sup>®</sup> M091 Series**, a Highly Integrated analog MCU  
with **Build-in OPA/ADC/DAC** for Sensor Application in Industrial  
Automation.



Photoelectric Sensor



Position Sensor



Pressure Sensor



Sensor Module

# NuMicro<sup>®</sup> M091 Series for Sensor Application in Industrial Automation

**S**mall Package Size: QFN33 4 mm x 4 mm & QFN48 5 mm x 5 mm

**H**igh Precision OPA: Offset Voltage 50  $\mu$ V

**E**conomic: MCU equipped with OPA, Temperature Sensor, and other Plentiful Analog Peripheral



## Strong Core

Arm<sup>®</sup> Cortex<sup>®</sup>-M0  
72 MHz, PLL 144 MHz



## Small Package

QFN33 4x4 mm  
QFN48 5x5 mm



## Powerful OPA

4 Sets of OPA  
Offset Voltage 50  $\mu$ V  
Gain Bandwidth 8 MHz



## Accurate Temp. Sensor

Build-in Temp. Sensor  
 $\pm 2$   $^{\circ}$ C (-40 $^{\circ}$ C to 105 $^{\circ}$ C)



## Plentiful Analog

16 Chs of 12-bit 2 Msps ADC  
4 Sets of 12-bit 1 Msps DAC

# NuMicro<sup>®</sup> M091 Series, a Highly Integrated Analog MCU with for Sensor Application in Industrial Automation

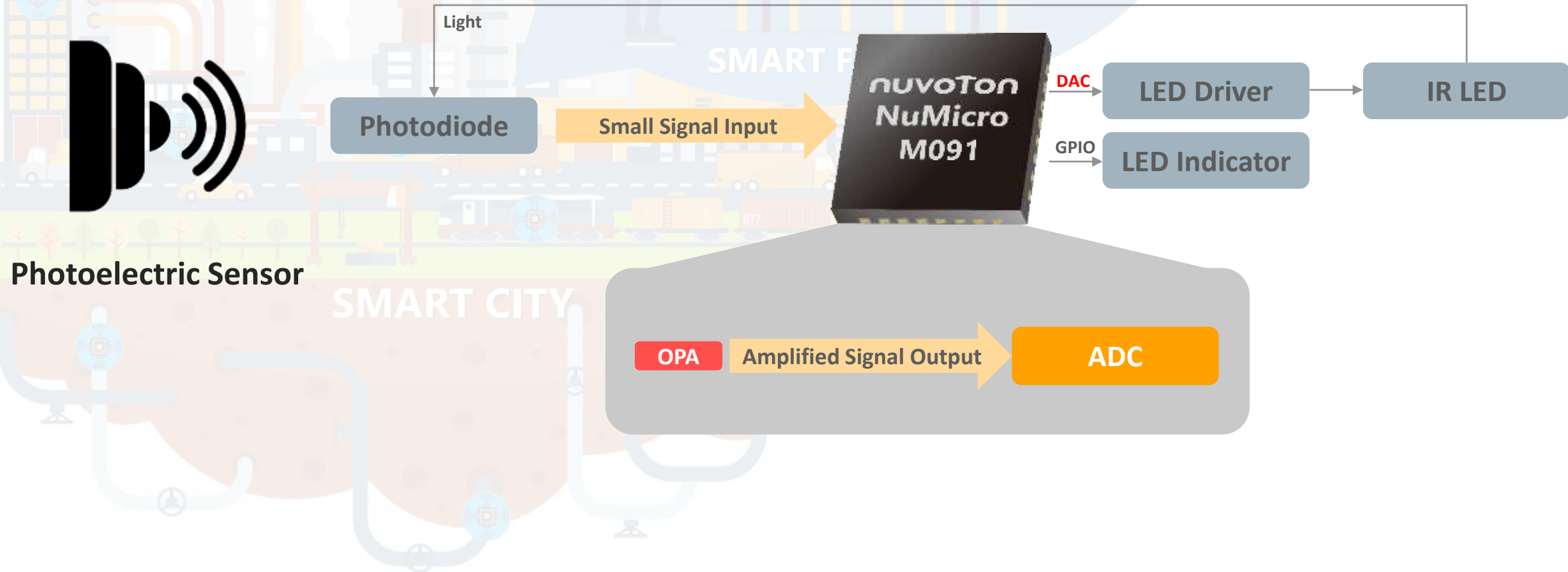

# Discrete Analog IC - for industrial control

NOP912/914 series High Precision Op Amp

NADC24 series Delta-Sigma 24-bit ADC



# NOP912/NOP914 Precision Op Amp



## Low Offset Voltage

- $\pm 50 \mu\text{V}$
- Reduced error in output



## Low Temperature Drift

- $0.05 \mu\text{V}/^\circ\text{C}$
- Accurate measurement is not affected by temperature



## Wide Unity-Gin BW

- **8 MHz**
- Capability of handling high BW signals



## Rail to Rail Input/Output

- **Input : 0V to VDD**
- **Output : 0.1V to VDD-0.1V**
- Maximize input range and output swing



## High Slew Rate

- **6V/ $\mu\text{s}$**
- Accurately amplifies fast changing signals

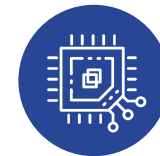

## Standard package

- NOP912: SOIC-8, **2 Amps**
- NOP914: TSSOP-14, **4 Amps**

- **Chopper-stabilized amplifier**
  - Minimizes input offset voltage and offset drift over time and temperature.
- **Operating temperature:**  $-40^\circ\text{C}$  to  $+105^\circ\text{C}$
- **Operating voltage:** 2.7V to 5.5V

# NOP912/914 Precision OP Amp for Motor Control

OP amp amplifies current sensor signals for monitoring

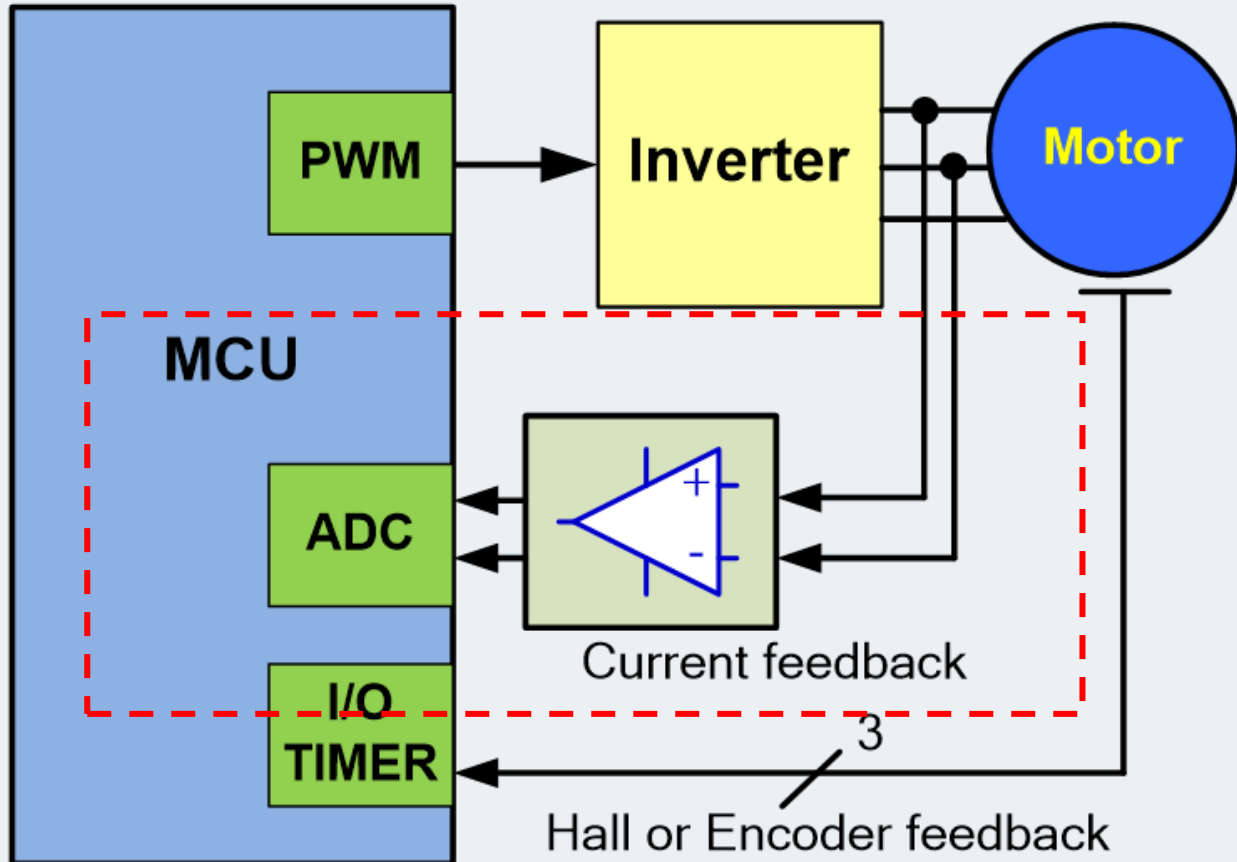

NOP912/914 Precision Op Amp' advantages

- Low input voltage offset: **50  $\mu\text{V}$** 
  - Monitoring currents accurately to enable precise control.
- Low input voltage temperature drift: **0.05  $\mu\text{V}/^\circ\text{C}$** 
  - Ensures stable control despite varying temperature changes.
- Wide Unity-Gain Bandwidth: **8 MHz**
  - Enable precise control of motor with rapid changes in direction & speed
- High slew rate: **6V/ $\mu\text{s}$** 
  - Allows the motor controller to respond quickly to changes in input



# NOP912/914 for Photoelectric Sensors

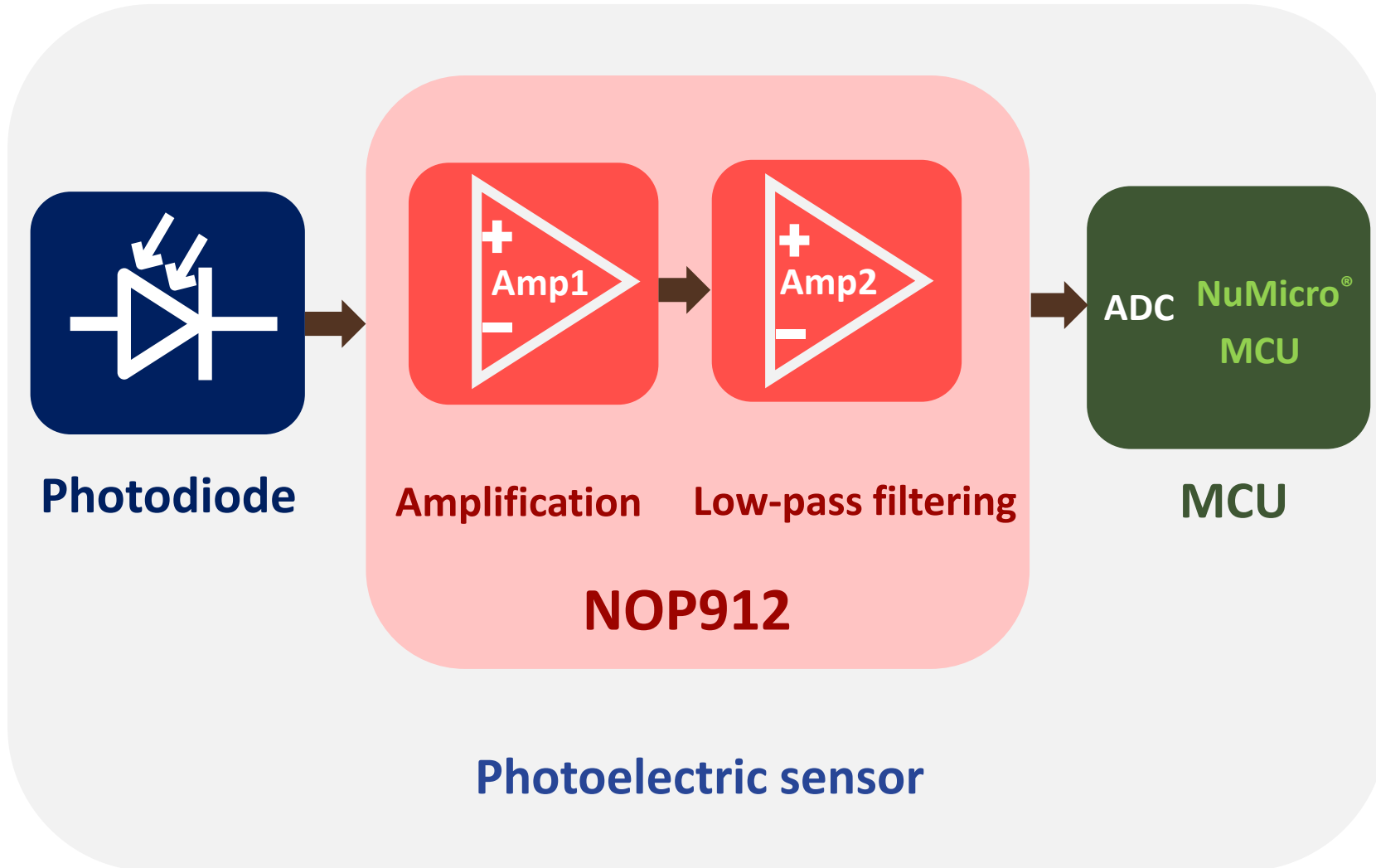

## NOP912/914 Advantages

- Multiple Op Amps in one chip
  - Two-stage Amplification
  - Noise reduction
  - Ant-aliasing
- NOP912 contains 2 amplifiers
- NOP914 contains 4 amplifiers
  - Effectively simplifies compact PCB design

# NADC24 24-bit Delta-sigma ADC



## Low noise

- ENOB up to 22-bit

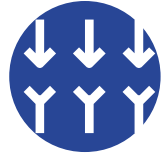

## Multiple channels

- Up to 8 single-ended ch.
- Up to 4 differential ch.



## High data rate

- Data rate up to 96 Ksps



## Integrated temperature sensor

- Up to  $\pm 2$  °C accuracy



## Internal voltage reference

- 1.2 V or 2.4 V



## Integrated DAC

- 12-bit DAC

- **24-bit Delta-sigma ADC**
  - High resolution, low noise
- **Operating temperature:**
  - -40 °C to +105 °C
- **Operating voltage:**
  - 2.7 V to 3.6 V

# NADC24 24-bit ADC for Precision Power Measurement

- Stable power supply is critical in industrial applications
  - Data center, production lines, fabs
- Precision power measurement is required
- NADC24's strengths
  - Low noise: ENOB up to 22-bit
  - High Speed: Output Data Rate up to 96 Ksps

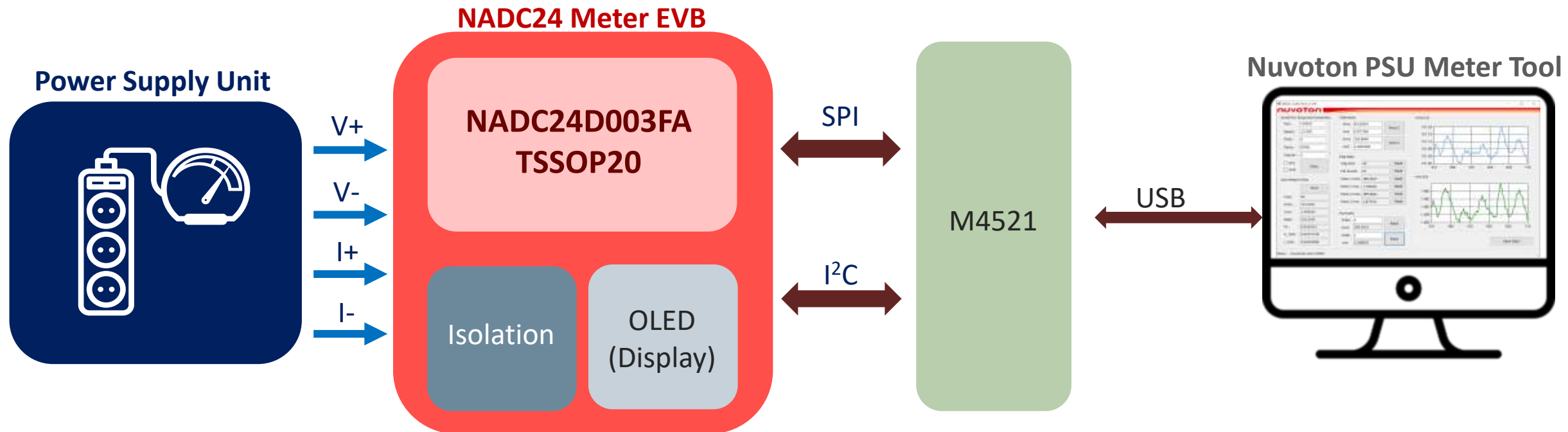

# NADC24 for precision weighing scales

- NADC24's outstanding low-noise performance: up to 22-bit ENOB
- For a load cell sensor of max. 50Kg, with NADC24, scale's output resolution can be as good as 0.1g.
- Low-power M254 MCU plus NADC24 make a perfect design of precision weighing scale.

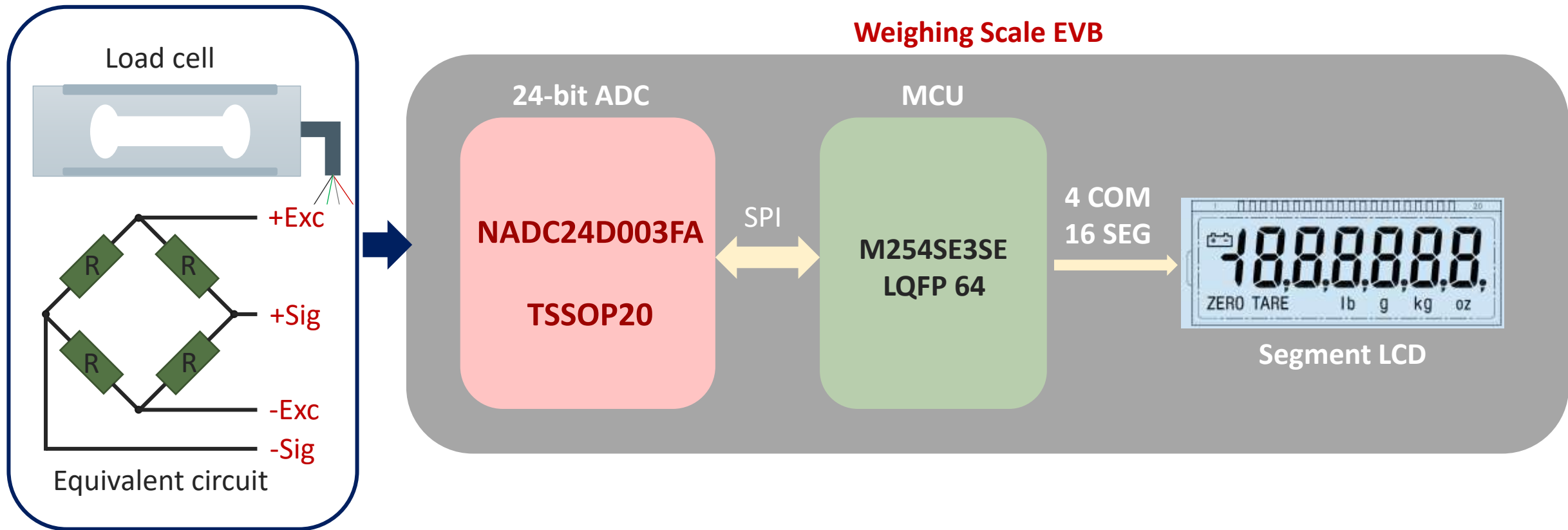

# NuMicro® NUC1263 Series MCU

Very first 5V MCU Support I3C interface

## High performance and 5V

72 MHz Arm® Cortex®-M23  
Operation Voltage 2.5V to 5.5V  
Operating Temp: -40°C to +105°C  
EFT 4.4 kV, ESD HBM 8 kV



## Advance Lighting interface

64 KB Flash/ 20 KB SRAM  
Support 6 CHs (LED Light Strip Interface, LLSI)  
Support 24 CHs 144 MHz PWM for precise industrial control

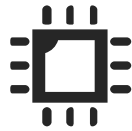

## Rich industrial Interface

10 CHs of PDMA  
3 sets of UART, 3 sets of I<sup>2</sup>C, 3 sets of SPI/ I<sup>2</sup>S  
**Support I3C Slave**  
16 CHs of 12-bit 800 kSPS ADC  
4 CHs of 8-bit 200 kSPS DAC  
4 sets of analog comparators (ACMP)



## USB 2.0 FS BC 1.2

Crystal-less USB 2.0 full speed device  
Compiling with USB Battery Charging Detection v1.2 (BC 1.2)  
for high-speed battery charging



## High Performance 5V MCU for industrial applications

- Arm® Cortex®-M23 72 MHz
- Operating Voltage: 2.5V to 5.5V
- Operating Temperature: -40°C to +105°C
- High interference immunity  
EFT 4.4 kV, ESD HBM 8 kV
- I3C slave support up to 12.5 MHz



Application: I3C Digital Sensor



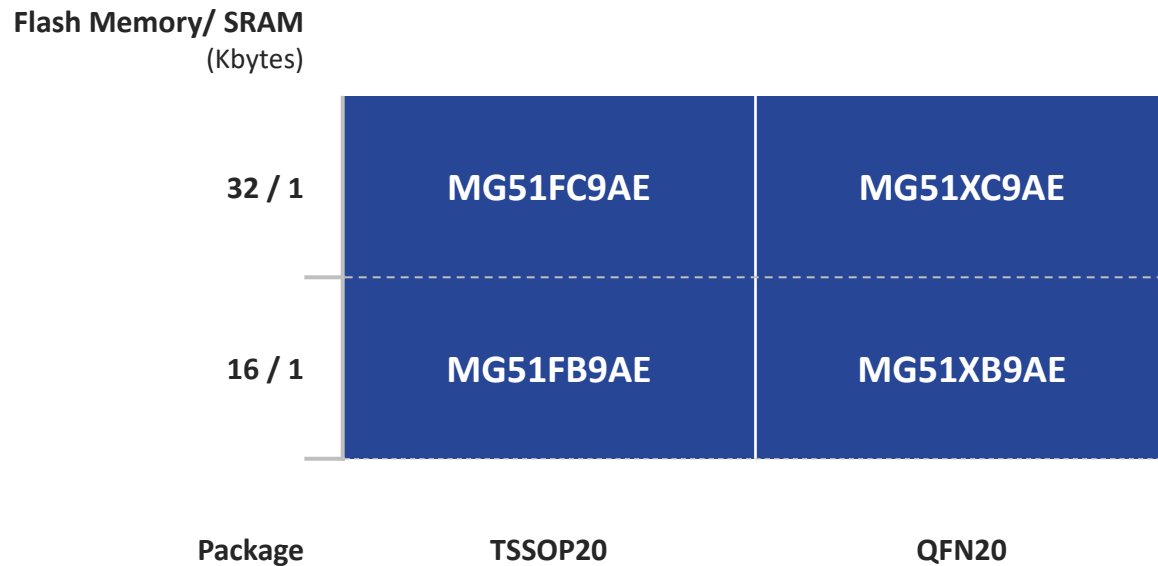

# NuMicro<sup>®</sup> MG51 Series MCU

Industrial-grade 8-bit MCU equipped with strong immunity



- 1T-8051 core
- Runs up to 24 MHz
- High immunity:  
EFT 4.4 kV, ESD HBM 7 kV
- 120  $\mu$ A/MHz in run mode.
- Rich peripherals:
  - 2 sets of UART
  - 6-channel 16-bit PWM
  - 8-channel 12-bit ADC
  - 4 sets of 16-bit timers
  - SPI, I<sup>2</sup>C
- Operating temperature:  
-40°C to +105°C
- Operating voltage:  
2.4V to 5.5V

# MG51 Product Portfolio Overview (2/2)

- Consistent Pinout**  
 With existed MS51
 
- Code Compatible**  
 With existed MS51
 
- Memory Extension**

- Low Power**  
 In Run mode
 

FLASH	SRAM	TSSOP14	TSSOP20	QFN20
32KB	2KB		MS51FC0AE	MS51XC0BE
32KB	1KB		MG51FC9AE	MG51XC9AE
<b>32K Flash, 1K RAM, 24MHz</b>				
18KB	1KB		N76E003AT20	N76E003AQ20 N76E003BQ20
16KB	1KB		MG51FB9AE	MG51XB9AE
<b>16K Flash, 1K RAM, 24MHz</b>				
16KB	1KB		MS51FB9AE	MS51XB9AE MS51XB9BE
8KB	1KB	MS51DA9AE		

# MG51 Product Portfolio Overview (1/2)

**Consistent Pinout**  
With existed MS51



**Code Compatible**  
With existed MS51



**Memory Extension**



**Low Power**  
In Run mode

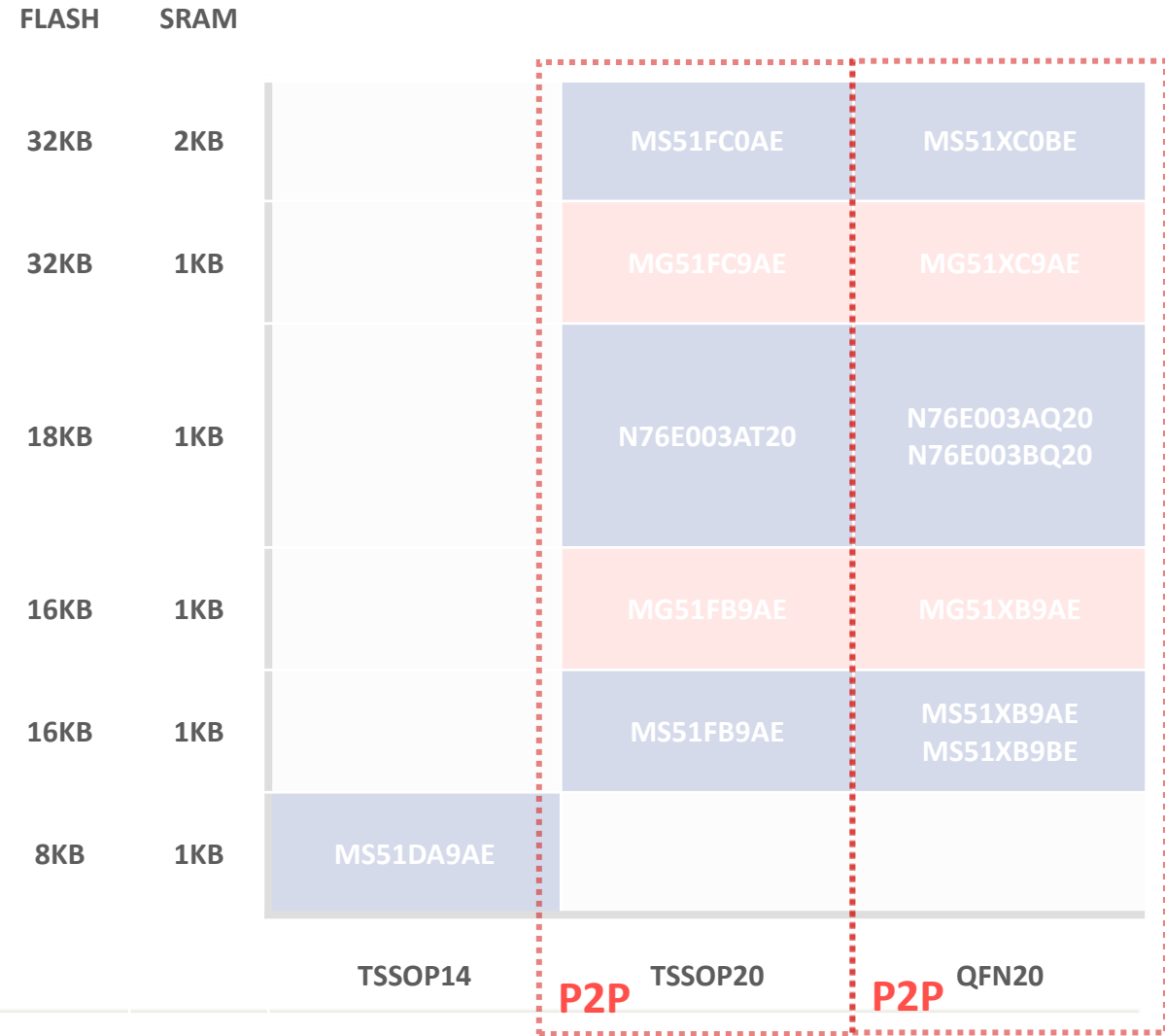

# | Why Choosing NuMicro for Industrial Control?

- Discrete analog NADC24, NOP
- I3C sensor hub NUC1263
- Highly integrated analog M091
- Strong immunity value up MG51

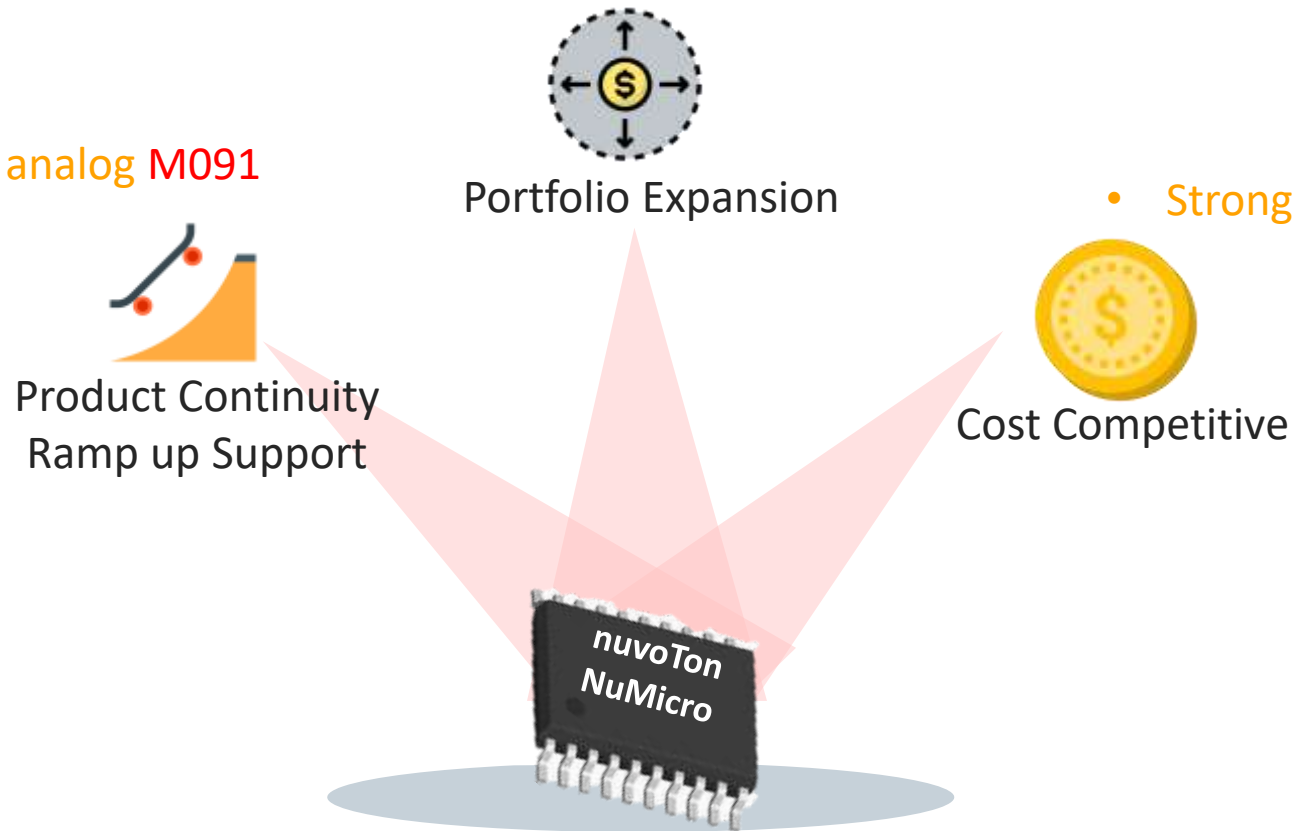

Joy of innovation  
**nuvoTon**

谢谢

謝謝

Děkuji

Bedankt

Thank you

Kiitos

Merci

Danke

Grazie

ありがとう

감사합니다

Dziękujemy

Obrigado

Спасибо

Gracias

Teşekkür ederim

Cảm ơn