

# NAU88C14

## Mono Audio Codec with Speaker Driver and Equalizer

### 1. GENERAL DESCRIPTION

NAU88C14 is a cost effective and low power wideband MONO audio CODEC. It is designed for voice telephony related applications. Functions include 5-band Graphic Equalizer, Automatic Level Control (ALC) with noise gate, PGA, standard audio interface I2S, PCM with time slot assignment, and on-chip PLL. The device provides one differential microphone input and one single ended auxiliary input (multi-purpose). There are few variable gain control stages in the audio path. It also includes MONO line output and integrated BTL speaker driver.

The analog inputs have PGA on the front end, allowing dynamic range optimization with a wide range of input sources. The microphone amplifiers have a programmable gain from -12dB to +35.25dB to handle both amplified microphones. In addition to a digital high pass filter to remove DC offset voltages, the ADC also features voice band digital filtering. Voice band data is accepted by the audio interface (I2S). The DAC converter path includes filtering and mixing, programmable-gain amplifiers (PGA), and soft muting. The digital interfaces, 2-Wire or SPI, have independent supply voltage to allow integration into multiple supply systems. NAU88C14 operates at supply voltages from 2.5V ~ 3.6V, although the digital core can operate at voltage as low as 1.71V to save power.

The NAU88C14 is specified for operation from -40°C ~ +85°C.

### 2. FEATURES

#### 24-bit signal processing linear Audio CODEC

- Audio DAC: 93dB SNR and -84dB THD
- Audio ADC: 91dB SNR and -79dB THD
- Support variable sample rates from 2.5 - 48kHz
- Integrated BTL Speaker Driver 1 W (8Ω / 5V)
- Integrated Headset Driver 40mW (16Ω / 3.3V)

#### Analog I/O

- Integrated programmable Microphone Amplifier
- Integrated Line Input and Line Output
- Earphone / Speaker / Line Output selection
- Microphone / Line Inputs selection
- Low Noise bias supplied for microphone
- On-chip PLL

#### Interfaces

- I<sup>2</sup>S digital interface PCM time slot assignment
- SPI & 2-Wire serial control Interface (I<sup>2</sup>C style; /Write capable)

#### Low Power, Low Voltage

- Analog Supply: 2.5V ~ 3.6V
- Digital Supply: 1.71V ~ 3.6V
- Nominal Operating Voltage: 3.3V

#### Additional features

- 5-band Graphic Equalizer
- Programmable ALC
- ADC Notch Filter
- Programmable High Pass Filter
- Digital A/D-D/A Pass-through
- Industrial temperature range: -40°C ~ +85°C
- Package is Halogen-free, RoHS-compliant and TSCA-compliant

#### Applications

- VoIP Telephones
- Conference speaker-phone
- IP PBX
- Mobile Telephone Hands-free Kits
- Residential & Consumer Intercoms

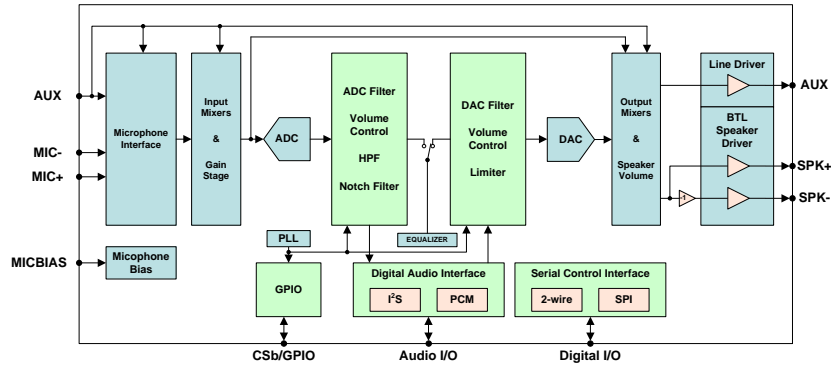

### 3. PIN CONFIGURATION

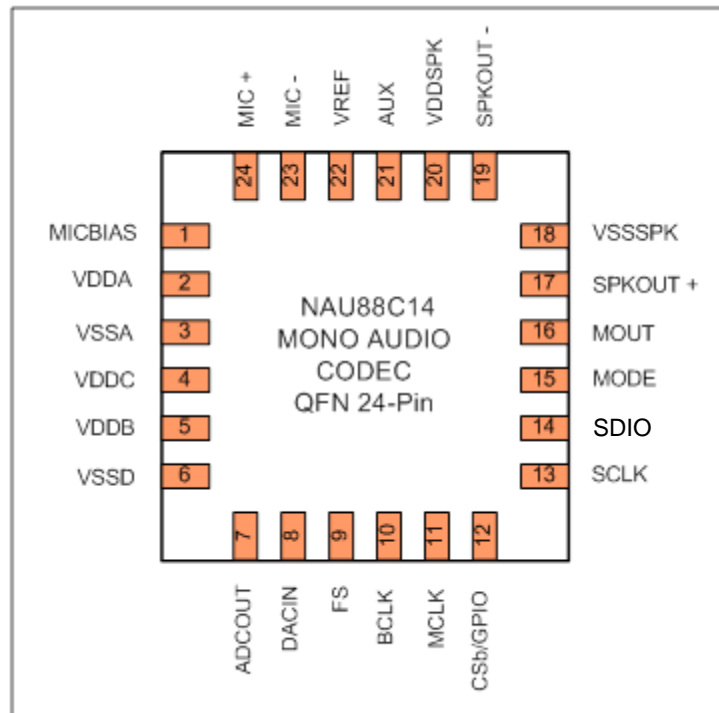

Figure 1: 24-Pin QFN Package

#### 4. PIN DESCRIPTION

Pin Name	24-Pin	Functionality	A/D	Pin Type
MICBIAS	1	Microphone Bias	A	O
VDDA	2	Analog Supply	A	I
VSSA	3	Analog Ground	A	O
VDDC	4	Digital Supply Core	D	I
VDDDB	5	Digital Supply Buffer	D	I
VSSD	6	Digital Ground	D	O
ADCOUT	7	Digital Audio Data Output	D	O
DACIN	8	Digital Audio Data Input	D	I
FS	9	Frame Sync	D	I/O
BCLK	10	Bit Clock	D	I/O
MCLK	11	Master Clock	D	I
CSB/GPIO	12	SPI Chip Select or General Purposes I/O	D	I/O
SCLK	13	SPI or 2-Wire Serial Clock	D	I
SDIO	14	SPI Data In or 2-Wire I/O	D	O
MODE	15	Interface Select (2-Wire or SPI)	D	I
MOUT	16	MONO Output	A	O
SPKOUT+	17	Speaker Positive Output	A	O
VSSSPK	18	Speaker Ground	A	O
SPKOUT-	19	Speaker Negative Output	A	O
VDDSPK	20	Speaker Supply	A	I
AUX	21	Auxiliary Input	A	I
VREF	22	Decoupling internal analog mid supply reference	A	O
MIC-	23	Microphone Negative Input	A	I
MIC+	24	Microphone Positive Input	A	I

Table 1: Pin Description

#### Notes

1. The 24-QFN package includes a bulk ground connection pad on the underside of the chip. This bulk ground should be thermally tied to the PCB, and electrically tied to the analog ground.
2. Unused analog input pins should be left as no-connection.
3. Under all condition when digital pins are not used they should be tied to ground.

5. BLOCK DIAGRAM

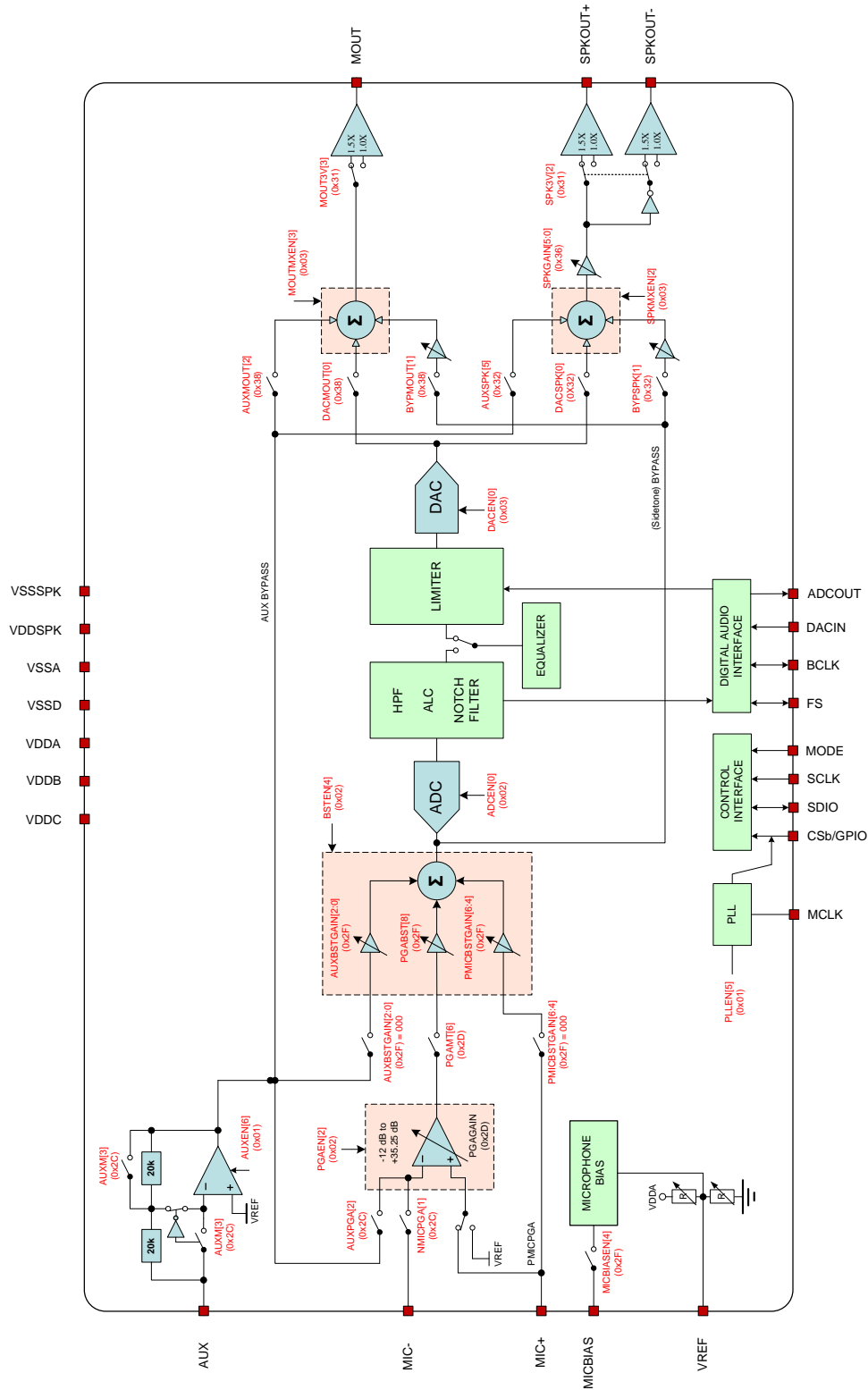

Figure 2: NAU88C14 General Block Diagram

## 6. Table of Contents

1.	GENERAL DESCRIPTION .....	1
2.	FEATURES .....	1
3.	PIN CONFIGURATION .....	2
4.	PIN DESCRIPTION .....	3
5.	BLOCK DIAGRAM .....	4
6.	TABLE OF CONTENTS .....	5
7.	LIST OF FIGURES .....	9
8.	LIST OF TABLES .....	11
9.	ABSOLUTE MAXIMUM RATINGS .....	12
10.	OPERATING CONDITIONS .....	12
11.	ELECTRICAL CHARACTERISTICS .....	13
12.	FUNCTIONAL DESCRIPTION .....	16
12.1.	INPUT PATH .....	16
12.1.1.	The Single Ended Auxiliary Input (AUX) .....	16
12.1.2.	The differential microphone input (MIC- & MIC+ pins) .....	18
12.1.2.1.	Positive Microphone Input (MIC+) .....	19
12.1.2.2.	Negative Microphone Input (MIC-) .....	19
12.1.2.3.	PGA Gain Control .....	20
12.1.3.	PGA Boost Stage .....	20
12.2.	MICROPHONE BIASING .....	22
12.3.	ADC DIGITAL FILTER BLOCK .....	23
12.3.1.	Programmable High Pass Filter (HPF) .....	24
12.3.2.	Programmable Notch Filter (NF) .....	24
12.3.3.	Digital ADC Gain Control .....	25
12.4.	PROGRAMMABLE GAIN AMPLIFIER (PGA) .....	25
12.4.1.	Automatic level control (ALC) .....	25
12.4.1.1.	Normal Mode .....	28
12.4.1.2.	ALC Hold Time (Normal mode Only) .....	28
12.4.2.	Peak Limiter Mode .....	29
12.4.3.	Attack Time .....	30
12.4.4.	Decay Times .....	30
12.4.5.	Noise gate (normal mode only) .....	30
12.4.6.	Zero Crossing .....	31
12.5.	DAC DIGITAL FILTER BLOCK .....	32
12.5.4.	Hi-Fi DAC De-Emphasis and Gain Control .....	33
12.5.5.	Digital DAC Output Peak Limiter .....	34
12.5.6.	Volume Boost .....	34
12.5.7.	5-Band Equalizer .....	35
12.6.	ANALOG OUTPUTS .....	36
12.6.1.	Speaker Mixer Outputs .....	36
12.6.2.	MONO Mixer Output .....	37
12.6.3.	Unused Analog I/O .....	38
12.7.	GENERAL PURPOSE I/O .....	39
12.7.1.	Slow Timer Clock .....	40
12.7.2.	Jack Detect .....	40

12.7.3.	Thermal Shutdown.....	41
12.8.	CLOCK GENERATION BLOCK.....	42
12.9.	CONTROL INTERFACE.....	46
12.9.1.	SPI Serial Control.....	46
12.9.1.1.	16-bit Write Operation (default).....	46
12.9.1.2.	24-bit Write Operation.....	47
12.9.2.	2-WIRE Serial Control Mode (I <sup>2</sup> C Style Interface).....	48
12.9.2.1.	2-WIRE Protocol Convention.....	48
12.9.2.2.	2-WIRE Write Operation.....	49
12.9.2.3.	2-WIRE Operation.....	50
12.10.	DIGITAL AUDIO INTERFACES.....	51
12.10.1.	Right Justified audio data.....	52
12.10.2.	Left Justified audio data.....	53
12.10.3.	I <sup>2</sup> S audio data.....	54
12.10.4.	PCM audio data.....	55
12.10.5.	PCM Time Slot audio data.....	56
12.10.6.	Companing.....	57
12.11.	POWER SUPPLY.....	58
12.11.1.	Power-On Reset.....	58
12.11.2.	Power Related Software Considerations.....	58
12.11.3.	Software Reset.....	59
12.11.4.	Power Up/Down Sequencing.....	59
12.11.5.	Reference Impedance (REFIMP) and Analog Bias.....	60
12.11.6.	Power Saving.....	60
12.11.7.	Estimated Supply Currents.....	61
13.	REGISTER DESCRIPTION.....	62
13.1.	SOFTWARE RESET.....	64
13.2.	POWER MANAGEMENT REGISTERS.....	64
13.2.1.	Power Management 1.....	64
13.2.2.	Power Management 2.....	65
13.2.3.	Power Management 3.....	65
13.3.	AUDIO CONTROL REGISTERS.....	65
13.3.1.	Audio Interface Control.....	65
13.3.2.	Audio Interface Companing Control.....	66
13.3.3.	Clock Control Register.....	67
13.3.4.	Audio Sample Rate Control Register.....	68
13.3.5.	GPIO Control Register.....	69
13.3.6.	DAC Control Register.....	69
13.3.7.	DAC Gain Control Register.....	70
13.3.8.	ADC Control Register.....	70
13.3.9.	ADC Gain Control Register.....	71
13.4.	5-BAND EQUALIZER CONTROL REGISTERS.....	72
13.5.	DIGITAL TO ANALOG CONVERTER (DAC) LIMITER REGISTERS.....	73
13.6.	NOTCH FILTER REGISTERS.....	74
13.7.	AUTOMATIC LEVEL CONTROL REGISTER.....	75
13.7.1.	ALC1 REGISTER.....	75

13.7.2.	ALC2 REGISTER .....	76
13.7.3.	ALC3 REGISTER .....	77
13.8.	NOISE GAIN CONTROL REGISTER .....	78
13.9.	PHASE LOCK LOOP (PLL) REGISTERS .....	79
13.9.1.	PLL Control Registers .....	79
13.9.2.	Phase Lock Loop Control (PLL) Registers .....	79
13.10.	INPUT, OUTPUT, AND MIXERS CONTROL REGISTER .....	80
13.10.1.	Attenuation Control Register .....	80
13.10.2.	Input Signal Control Register .....	80
13.10.3.	PGA Gain Control Register .....	81
13.10.4.	ADC Boost Control Registers .....	82
13.10.5.	Output Register .....	82
13.10.6.	Speaker Mixer Control Register .....	83
13.10.7.	Speaker Gain Control Register .....	83
13.10.8.	MONO Mixer Control Register .....	84
13.10.9.	Power Management 4 .....	84
13.11.	PCM TIME SLOT CONTROL & ADCOUT IMPEDANCE OPTION CONTROL .....	85
13.11.1.	PCM1 TIMESLOT CONTROL REGISTER .....	85
13.11.2.	PCM2 TIMESLOT CONTROL REGISTER .....	85
13.12.	REGISTER ID .....	86
13.12.1.	Device revision register .....	86
13.12.2.	2-WIRE ID Register .....	86
13.12.3.	Additional ID .....	86
13.13.	Reserved .....	86
13.14.	OUTPUT Driver Control Register .....	87
13.15.	AUTOMATIC LEVEL CONTROL ENHANCED REGISTER .....	88
13.15.1.	ALC1 Enhanced Register .....	88
13.15.2.	ALC Enhanced 2 Register .....	88
13.16.	MISC CONTROL REGISTER .....	89
13.17.	Output Tie-Off REGISTER .....	90
13.18.	AGC PEAK-TO-PEAK OUT REGISTER .....	90
13.19.	AGC PEAK OUT REGISTER .....	90
13.20.	AUTOMUTE CONTROL AND STATUS REGISTER .....	91
13.21.	Output Tie-off Direct Manual Control REGISTER .....	91
14.	CONTROL INTERFACE TIMING DIAGRAM .....	92
14.1.	SPI WRITE TIMING DIAGRAM .....	92
14.2.	2-WIRE TIMING DIAGRAM .....	93
15.	AUDIO INTERFACE TIMING DIAGRAM .....	94
15.1.	AUDIO INTERFACE IN SLAVE MODE .....	94
15.2.	AUDIO INTERFACE IN MASTER MODE .....	94
15.3.	PCM AUDIO INTERFACE IN SLAVE MODE (PCM Audio Data) .....	95
15.4.	PCM AUDIO INTERFACE IN MASTER MODE (PCM Audio Data) .....	95
15.5.	PCM AUDIO INTERFACE IN SLAVE MODE (PCM Time Slot Mode) .....	96
15.6.	PCM AUDIO INTERFACE IN MASTER MODE (PCM Time Slot Mode) .....	96
15.7.	System Clock (MCLK) Timing Diagram .....	97
15.8.	μ-LAW ENCODE DECODE CHARACTERISTICS .....	98
15.9.	A-LAW ENCODE DECODE CHARACTERISTICS .....	99

15.10. $\mu$ -LAW / A-LAW CODES FOR ZERO AND FULL SCALE .....	100
15.11. $\mu$ -LAW / A-LAW OUTPUT CODES (DIGITAL MW) .....	100
16. DIGITAL FILTER CHARACTERISTICS .....	101
17. TYPICAL APPLICATION .....	103
18. PACKAGE SPECIFICATION .....	104
19. ORDERING INFORMATION .....	105
20. REVISION HISTORY .....	106
IMPORTANT NOTICE .....	108



## 7. List of Figures

---

Figure 1: 24-Pin QFN Package .....	2
Figure 2: NAU88C14 General Block Diagram .....	4
Figure 3: Auxiliary Input Circuit Block Diagram with AUXM[3] = 0 .....	17
Figure 4: Auxiliary Input Circuit Block Diagram with AUXM[3] = 1 .....	17
Figure 5: Input PGA Circuit Block Diagram .....	18
Figure 6: Boost Stage Block Diagram .....	20
Figure 7: Microphone Bias Schematic.....	22
Figure 8: ADC Digital Filter Path Block Diagram.....	23
Figure 9: ALC Block Diagram.....	26
Figure 10: ALC Response Graph.....	26
Figure 11: ALC Normal Mode Operation.....	28
Figure 12: ALC Hold Time.....	29
Figure 13: ALC Limiter Mode Operations.....	29
Figure 14: ALC Operation with Noise Gate disabled.....	30
Figure 15: ALC Operation with Noise Gate Enabled.....	31
Figure 16: DAC Digital Filter Path .....	32
Figure 17: DAC Digital Limiter Control .....	34
Figure 18: Speaker and MONO Analogue Outputs.....	36
Figure 19: Tie-off Options for the Speaker and MONO output Pins .....	38
Figure 20: PLL and Clock Select Circuit.....	42
Figure 21: Register write operation using a 16-bit SPI Interface .....	47
Figure 22: Register Write operation using a 24-bit SPI Interface .....	48
Figure 23: Valid START Condition .....	49
Figure 24: Valid Acknowledge.....	49
Figure 25: Valid STOP Condition .....	49
Figure 26: Slave Address Byte, Control Address Byte, and Data Byte .....	49
Figure 27: Byte Write Sequence .....	49
Figure 28: 2-Wire Read Sequence.....	50
Figure 29: Right Justified Audio Interface (Normal Mode).....	52
Figure 30: Right Justified Audio Interface (Special mode) .....	52
Figure 31: Left Justified Audio Interface (Normal Mode).....	53
Figure 32: Left Justified Audio Interface (Special mode).....	53
Figure 33: I2S Audio Interface (Normal Mode).....	54
Figure 34: I2S Audio Interface (Special mode).....	54
Figure 35: PCM Mode Audio Interface (Normal Mode) .....	55
Figure 36: PCM Mode Audio Interface (Special mode).....	55

Figure 37: PCM Time Slot Mode (Time slot = 0) (Normal Mode) .....	56
Figure 38: PCM Time Slot Mode (Time slot = 0) (Special mode) .....	56
Figure 39: The Programmable ADCOUT Pin .....	85
Figure 40: SPI Write Timing Diagram.....	92
Figure 41: 2-Wire Timing Diagram .....	93
Figure 42: Audio Interface Slave Mode Timing Diagram.....	94
Figure 43: Audio Interface in Master Mode Timing Diagram .....	94
Figure 44: PCM Audio Interface Slave Mode Timing Diagram .....	95
Figure 45: PCM Audio Interface Slave Mode Timing Diagram .....	95
Figure 46: PCM Audio Interface Slave Mode (PCM Time Slot Mode )Timing Diagram.....	96
Figure 47: PCM Audio Interface Master Mode (PCM Time Slot Mode )Timing Diagram.....	96
Figure 48: MCLK Timing Diagram.....	97
Figure 49: DAC Filter Frequency Response .....	102
Figure 50: ADC Filter Frequency Response .....	102
Figure 51: DAC Filter Ripple .....	102
Figure 52: ADC Filter Ripple .....	102
Figure 53: Application Diagram For 24-Pin QFN.....	103

## 8. List of Tables

---

Table 1: Pin Description .....	3
Table 2: Register associated with Input PGA Control .....	18
Table 3: Microphone Non-Inverting Input Impedances.....	19
Table 4: Microphone Inverting Input Impedances .....	19
Table 5: Registers associated with ALC and Input PGA Gain Control .....	20
Table 6: Registers associated with PGA Boost Stage Control .....	21
Table 7: Register associated with Microphone Bias.....	22
Table 8: Microphone Bias Voltage Control.....	23
Table 9: Register associated with ADC.....	24
Table 10: High Pass Filter Cut-off Frequencies (HPFAM=1).....	24
Table 11: Registers associated with Notch Filter Function.....	24
Table 12: Equations to Calculate Notch Filter Coefficients .....	25
Table 13: Register associated with ADC Gain .....	25
Table 14: Registers associated with ALC Control .....	27
Table 15: ALC Maximum and Minimum Gain Values.....	27
Table 16: Registers associated with DAC Gain Control.....	32
Table 17: Registers associated with Equalizer Control .....	35
Table 18: Speaker Output Controls.....	37
Table 19: MONO Output Controls .....	37
Table 20: General Purpose Control.....	40
Table 21: Jack Insert Detect mode.....	40
Table 22: Jack Insert Detect controls .....	41
Table 23: Thermal Shutdown .....	41
Table 24: Registers associated with PLL .....	43
Table 25: Registers associated with PLL .....	44
Table 26: PLL Frequency Examples .....	45
Table 27: Control Interface Selection .....	46
Table 28: Standard Interface modes .....	51
Table 29: Audio Interface Control Registers .....	51
Table 30: Comanding Control .....	57
Table 31: Power up sequence.....	60
Table 32: Power down Sequence .....	60
Table 33: Registers associated with Power Saving.....	61
Table 34: VDDA 3.3V Supply Current .....	61
Table 35: SPI Timing Parameters .....	92
Table 36: 2-WireTiming Parameters .....	93
Table 37: Audio Interface Timing Parameters.....	97
Table 38: MCLK Timing Parameter.....	97

## 9. ABSOLUTE MAXIMUM RATINGS

CONDITION	MIN	MAX	Units
VDDDB, VDDC, VDDA supply voltages	-0.3	+3.63	V
VDDSPK supply voltage (MOUTBST=0, SPKBST=0)	-0.3	+3.63	V
VDDSPK supply voltage (MOUTBST=1, SPKBST=1)	-0.3	+5.50	V
Core Digital Input Voltage range	VSSD – 0.3	VDDC + 0.30	V
Buffer Digital Input Voltage range	VSSD – 0.3	VDDDB + 0.30	V
Analog Input Voltage range	VSSA – 0.3	VDDA + 0.30	V
Industrial operating temperature T <sub>A</sub>	-40	+85	°C
Junction Temperature T <sub>J</sub>	-40	+150	°C
Storage temperature range	-65	+150	°C

**CAUTION:** Do not operate at or near the maximum ratings listed for extended period of time. Exposure to such conditions may adversely influence product reliability and result in failures not covered by warranty. These devices are sensitive to electrostatic discharge; follow proper IC Handling Procedures.

## 10. OPERATING CONDITIONS

Condition	Symbol	Min Value	Typical Value	Max Value	Units
Analogue supplies range	VDDA	2.50 <sup>1</sup>		3.60	V
Digital supply range (Buffer)	VDDDB	1.71 <sup>2</sup>		3.60	V
Digital supply range (Core)	VDDC	1.71		3.60	V
Speaker supply	VDDSPK	2.50	3.30/5.00 <sup>3</sup>	5.50	V
Ground	VSSD VSSA VSSSPK		0		V

1. VDDA must be  $\geq$  VDDC.

2. VDDDB must be  $\geq$  VDDC.

3. For VDDSPK typical values:

MOUTBST=0 and SPKBST=0, VDDSPK=3.30V.

MOUTBST=1 or SPKBST=1 or both, VDDSPK=5.00V.

## 11. ELECTRICAL CHARACTERISTICS

VDDC = 1.8V, VDDA = VDDB = VDDSPK = 3.3V (VDDSPK = 1.5\*VDDA when Boost), T<sub>A</sub> = +25°C, 1kHz signal, fs = 48kHz, 24-bit audio data unless otherwise stated.

PARAMETER	SYMBOL	TEST CONDITIONS	MIN	TYP	MAX	UNIT
<b>Analogue to Digital Converter (ADC)</b>						
Full scale input signal <sup>1</sup>	V <sub>INFS</sub>	PGABST = 0dB PGAGAIN = 0dB		1.0 0		V <sub>RMS</sub> dBV
Signal to Noise Ratio <sup>2</sup>	SNR	Gain = 0dB, A-weighted	87	91		dB
Total Harmonic Distortion <sup>3</sup>	THD	Input = -1dBFS, Gain = 0dB		-79	-65	dB
<b>Digital to Analogue Converter (DAC) to MONO output (all data measured with 10kΩ / 50pF load)</b>						
Full Scale output signal <sup>1</sup>		MOUTBST=0		1.0x (V <sub>REF</sub> )		V <sub>RMS</sub>
		MOUTBST=1		1.5 x V <sub>REF</sub>		
Signal to Noise Ratio <sup>2</sup>	SNR	A-weighted (ADC/DAC oversampling rate of 128)	90	93		dB
Total Harmonic Distortion <sup>3</sup>	THD	R <sub>L</sub> = 10 kΩ; -1.0dBfs		-84	-70	dB
<b>Auxiliary Analogue Input (AUX)</b>						
Full-scale Input Signal Level <sup>1</sup>	V <sub>INFS</sub>	Gain = 0dB		1 0		V <sub>RMS</sub> dBV
Input Resistance	R <sub>AUX</sub>	AUXM=0		20		kΩ
Input Capacitance	C <sub>AUX</sub>			10		pF
<b>Microphone Inputs (MICN &amp; MICP) and MIC Input Programmable Gain Amplifier (PGA)</b>						
Full-scale Input Signal Level <sup>1</sup>	V <sub>INFS</sub>	PGABST = 0dB PGAGAIN = 0dB		1 0		V <sub>RMS</sub> dBV
Programmable input PGA gain			-12		35.25	dB
Programmable Gain Step Size		Guaranteed monotonic		0.75		dB
Programmable Boost PGA gain		PGABST = 0		0		dB
		PGABST = 1		20		
Mute Attenuation				100		dB
PGA equivalent output noise		0 to 20kHz, Gain set to 35.25dB		110		μV
Auxiliary Input resistance	R <sub>AUX</sub>	PGA Gain = 35.25dB		1.6		kΩ
		PGA Gain = 0dB		47		kΩ
		PGA Gain = -12dB		75		kΩ
Positive Microphone Input resistance	R <sub>MIC+</sub>	PMICPGA = 1		94		kΩ
Input Capacitance	C <sub>MIC</sub>			10		pF
<b>Speaker Output PGA</b>						
Programmable Gain			-57		6	dB
Programmable Gain Step Size		Guaranteed monotonic		1		dB

VDDC = 1.8V, VDDA = VDDDB = VDDSPK = 3.3V (VDDSPK = 1.5\*VDDA when Boost), T<sub>A</sub> = +25°C, 1kHz signal, f<sub>s</sub> = 48kHz, 24-bit audio data unless otherwise stated.

PARAMETER	SYMBOL	TEST CONDITIONS			MIN	TYP	MAX	UNIT	
<b>BTL Speaker Output (SPKOUT+, SPKOUT- with 8Ω bridge tied load)</b>									
Full scale output <sup>7</sup>		SPKBST = 0 VDDSPK = VDDA			VDDA / 3.3		V <sub>RMS</sub>		
		SPKBST = 1 VDDSPK = 1.5*VDDA			(VDDA / 3.3) * 1.5				
Output Power	PO	Output power is very closely correlated with THD; see below							
Signal to Noise Ratio	SNR	VDDSPK = 3.3V RL = 8Ω				90		dB	
		VDDSPK = 1.5*VDDA RL = 8Ω				90		dB	
Total Harmonic Distortion	THD	PO = 180mW	RL = 8Ω	VDDSPK=3.3V		-63		dB	
		PO = 400mW				-56		dB	
		PO = 360mW		VDDSPK = 1.5*VDDA			-60		dB
		PO = 800mW					-61		dB
		PO = 1W					-34		dB
Power Supply Rejection Ratio (50Hz – 22kHz)	PSRR	VDDSPK = 3V, SPKBST = 0				50		dB	
		VDDSPK = 1.5*VDDA, SPKBST = 1				50		dB	
<b>Headphone' output (SPKOUTP, SPKOUTN with resistive load to ground)</b>									
Full scale output <sup>7</sup>					VDDA / 3.3			V <sub>RMS</sub>	
Signal to Noise Ratio	SNR	A-weighted				90		dB	
Total Harmonic Distortion	THD	P <sub>o</sub> = 20mW	RL=16Ω	VDDSPK=3.3V		-84		dB	
		P <sub>o</sub> = 20mW	RL=32Ω				-85		dB
<b>Microphone Bias</b>									
Bias Voltage	V <sub>MICBIAS</sub>	(MICBIASV = 0)				0.9* VDD A		V	
		(MICBIASV = 1)				0.65* VDD A		V	
Bias Current Source	I <sub>MICBIAS</sub>					3		mA	
Output Noise Voltage	V <sub>N</sub>	MICBIASM = 0 (1kHz to 20kHz)				14		nV/√Hz	
		MICBIASM = 1 (1kHz to 20kHz)				4		nV/√Hz	
<b>Automatic Level Control (ALC)/Limiter – ADC only</b>									
Target Record Level					-28.5		-6	dB	
Programmable Gain					-12		35.25	dB	
Programmable Gain Step Size		Guaranteed Monotonic				0.75		dB	
Gain Hold Time <sup>4, 6</sup>	t <sub>HOLD</sub>	MCLK=12.288MHz			0 / 2.67 / ... / 43691 (time doubles with each step)			ms	

VDDC = 1.8V, VDDA = VDDDB = VDDSPK = 3.3V (VDDSPK = 1.5\*VDDA when Boost), T<sub>A</sub> = +25°C, 1kHz signal, fs = 48kHz, 24-bit audio data unless otherwise stated.

PARAMETER	SYMBOL	TEST CONDITIONS	MIN	TYP	MAX	UNIT
<b>Automatic Level Control (ALC)/Limiter – ADC only</b>						
Gain Ramp-Up (Decay) Time <sup>5, 6</sup>	t <sub>DCY</sub>	ALC Mode ALCM=0 MCLK=12.288MHz	3.3 / 6.6 / 13.1 / ... / 3360 (time doubles every step)			ms
		Limiter Mode ALCM=1 MCLK=12.288MHz	0.73 / 1.45 / 2.91 / ... / 744 (time doubles every step)			ms
Gain Ramp-Down (Attack) Time <sup>5, 6</sup>	t <sub>ATK</sub>	ALC Mode ALCM=0 MCLK=12.288MHz	0.83 / 1.66 / 3.33 / ... / 852 (time doubles every step)			ms
		Limiter Mode ALCM=1 MCLK=12.288MHz	0.18 / 0.36 / 0.73 / ... / 186 (time doubles every step)			ms
<b>Digital Input / Output</b>						
Input HIGH Level	V <sub>IH</sub>		0.7 × VDDB			V
Input LOW Level	V <sub>IL</sub>				0.3 × VDDB	V
Output HIGH Level	V <sub>OH</sub>	I <sub>OL</sub> = 1mA	0.9 × VDDB			V
Output LOW Level	V <sub>OL</sub>	I <sub>OH</sub> = -1mA			0.1 × VDDB	V

**Notes**

1. Full Scale is relative to VDDA (FS = VDDA/3.3.). Input level to AUX is limited to a maximum of -3dB so that THD+N performance will not be reduced.
2. Signal-to-noise ratio (dB) – SNR is a measure of the difference in level between the full-scale output and the output with no signal applied. (No Auto-zero or Automute function is employed in achieving these results).
3. THD+N (dB) – THD+N are a ratio, of the rms values, of (Noise + Distortion)/Signal.
4. Hold Time is the length of time between a signal detected being too quiet and beginning to ramp up the gain. It does not apply to ramping down the gain when the signal is too loud, which happens without a delay.
5. Ramp-up and Ramp-Down times are defined as the time it takes to change the PGA gain by 6dB of its gain range.
6. All hold, ramp-up and ramp-down times scale proportionally with MCLK
7. The maximum output voltage can be limited by the speaker power supply. If MOUTBST or SPKBST is, set then VDDSPK should be 1.5xVDDA to prevent clipping taking place in the output stage (when PGA gains are set to 0dB).

## 12. FUNCTIONAL DESCRIPTION

The NAU88C14 is a MONO Audio CODEC with very robust ADC and DAC. The device provides one single ended auxiliary input (AUX pin) and one differential microphone input (MIC- & MIC+ pins). The auxiliary input (AUX) can be configured to sum multiple signals into a single input. It has three different amplification paths with a total gain of up to +55.25dB. The differential input also has amplification paths similar to auxiliary input.

The device also has an internal configurable biasing circuit for biasing the microphone, which in turn reduces external components. The PGA output has programmable ADC gain. An advanced Sigma Delta DAC is used along with digital decimation and interpolation filters to give high quality audio at sample rates from 8 kHz to 48 kHz. The Digital Filter blocks include ADC high pass filters, and Notch filter, and a 5-band equalizer. The device has two output mixers, one for MONO output and the other for the speaker output. It also has one input mixer.

The NAU88C14 has two different types of serial control interface 2-Wire and SPI for device control. 2-Wire and SPI are hardware selectable through MODE pin on the device. The device also supports I<sup>2</sup>S, PCM time slotting, Left Justified and Right Justified for audio interface.

The device can operate as a master or slave device. It can operate with sample rates ranging from 8 kHz to 48 kHz, depending on the values of MCLK and its prescaler. The NAU88C14 includes a PLL block, where it takes the external clock (MCLK pin) to generate other clocks for the audio data transfer such as Bit clock (BCLK), Frame sync (FS), and I<sup>2</sup>S clocks. The PLL can also configure a separate programmable clock for the use in the system through CSb/GPIO pin. The power control registers help save power by controlling the major individual functional blocks of the NAU88C14.

### 12.1. INPUT PATH

The NAU88C14 has two different types of microphone inputs single ended and differential. Figure 3 shows the different paths that the input signals can take.

All inputs are maintained at a DC bias at approximately half of the VDDA supply voltage. Connections to these inputs should be AC-coupled by means of DC blocking capacitors suitable for the device application.

#### 12.1.1. The Single Ended Auxiliary Input (AUX)

The single ended auxiliary input (AUX) has three different paths to MONO output (MOUT).

- Directly connected to the MONO Mixer or Speaker Mixer to MOUT or SPKOUT+ and SPKOUT- respectively
- Connect through the PGA Boost Mixer which has a range of -12dB to +6dB
- Connect through both the input PGA Gain (range of -12dB to +35.25 dB) and PGA Boost Mixer (range of 0db or +20dB)



The last two paths above go through the ADC filters where the ALC loop controls the amplitude of the input signal. The device also has an internal configurable biasing circuit for biasing the microphone, reducing external components.

An internal inverting operational amplifier circuit allows the auxiliary input pin to connect multiple signals for mixing. This can be achieved by setting AUXM[3] address (0x2C) to LOW. The combination of the 20k ohm resistors can vary due to process variation in the gain stage. The block can also be configured to be used as a buffer by setting AUXM[3] address (0x2C) to HIGH. The internal inverting circuit block can be enable/disable by setting AUXEN[6] address (0x01).

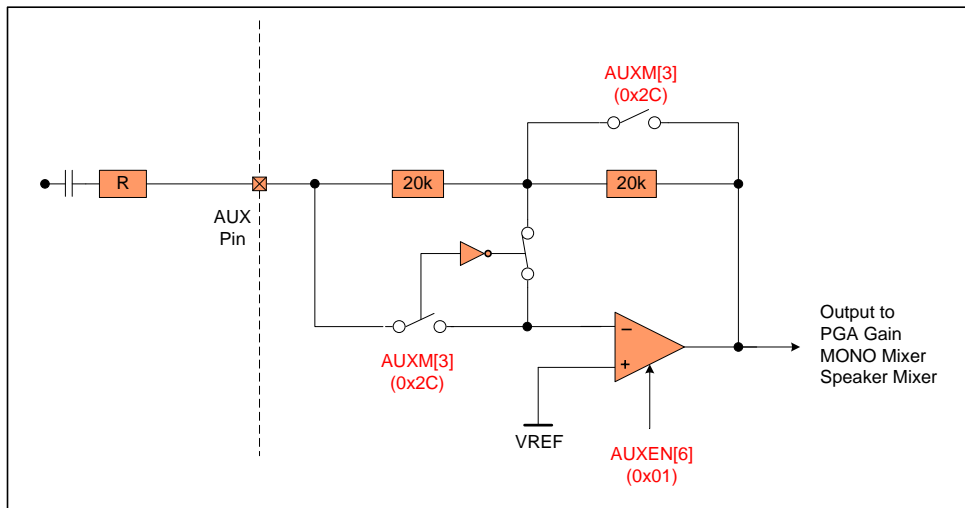

Figure 3: Auxiliary Input Circuit Block Diagram with AUXM[3] = 0

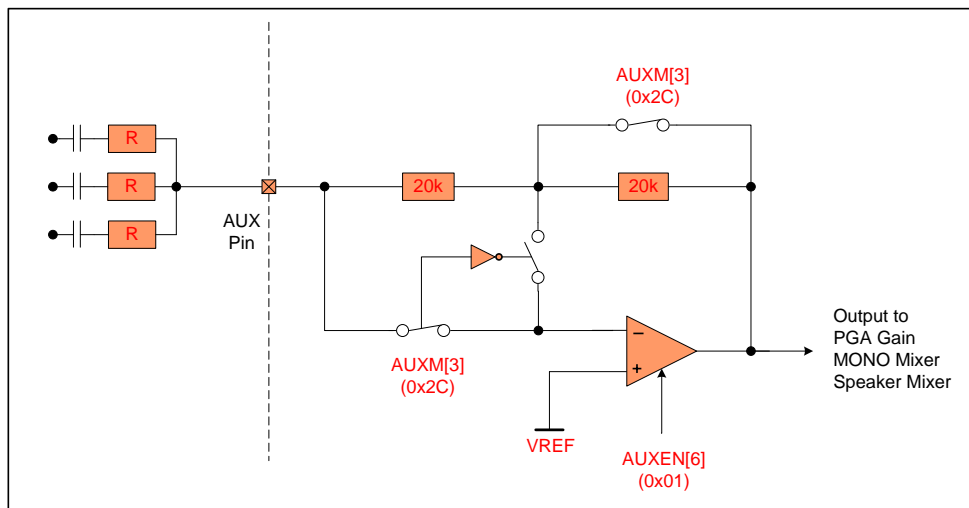

Figure 4: Auxiliary Input Circuit Block Diagram with AUXM[3] = 1

## 12.1.2. The differential microphone input (MIC- & MIC+ pins)

The NAU88C14 features a low-noise, high common mode rejection ratio (CMRR), differential microphone inputs (MIC- & MIC+ pins) which are connected to a PGA Gain stage. The differential input structure is essential in noisy digital systems where amplification of low-amplitude analog signals is necessary such as notebooks and PDAs. When properly employed, the differential input architecture offers an improved power-supply rejection ratio (PSRR) and higher ground noise immunity.

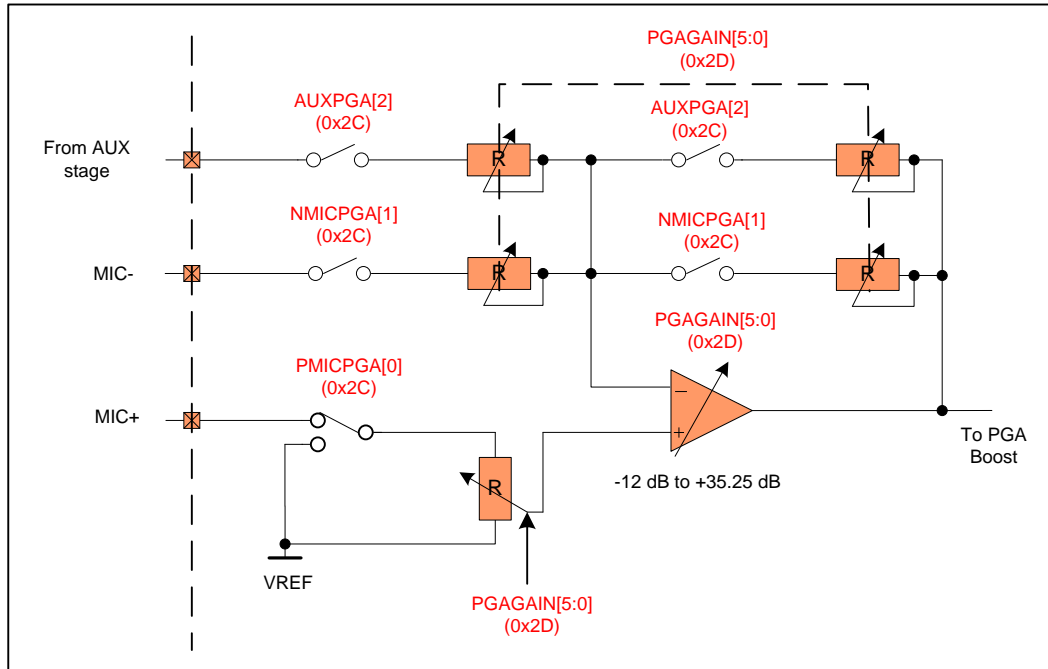

Figure 5: Input PGA Circuit Block Diagram

Bit(s)	Addr	Parameter	Programmable Range
PMICPGA[0]	0x2C	Positive Microphone to PGA	0 = Input PGA Positive terminal to VREF 1 = Input PGA Positive terminal to MICP
NMICPGA[1]	0x2C	Negative Microphone to PGA	0 = MICN not connected to input PGA 1 = MICN to input PGA Negative terminal.

Table 2: Register associated with Input PGA Contro

### 12.1.2.1. Positive Microphone Input (MIC+)

The positive microphone input (MIC+) can be used as part of the differential input. It connects to the positive terminal of the PGA gain amplifier by setting PMICPGA[0] address (0x2C) to HIGH or can be connected to VREF by setting PMICPGA[0] address (0x2C) to LOW.

When the associated control bit is set logic = 1, the MIC+ pin is connected to a resistor of approximately 1k $\Omega$  which is tied to VREF. The purpose of the tie to VREF is to reduce any pop or click sound by keeping the DC level of the MIC+ pin close to VREF at all times.

Note: In single ended applications where the MIC+ input is used without using MIC-, the PGA gain values will be valid only if the MIC- pin is terminated to a low impedance signal point. This termination should normally be an AC coupled path to signal ground. This input impedance is constant regardless of the gain value. The following table gives the nominal input impedance for this input. Impedance for specific gain values not listed in this table can be estimated through interpolation between listed values.

MIC+ to non-inverting PGA input Nominal Input Impedance	
Gain (dB)	Impedance (k $\Omega$ )
-12	94
-9	94
-6	94
-3	94
0	94
3	94
6	94
9	94
12	94
18	94
30	94
35.25	94

Table 3: Microphone Non-Inverting Input Impedances

MIC- to inverting PGA input Nominal Input Impedance	
Gain (dB)	Impedance (k $\Omega$ )
-12	75
-9	69
-6	63
-3	55
0	47
3	39
6	31
9	25
12	19
18	11
30	2.9
35.25	1.6

Table 4: Microphone Inverting Input Impedances

### 12.1.2.2. Negative Microphone Input (MIC-)

The negative microphone input (MIC-) has two distinctive configuration; differential input or single ended input. This input connects to the negative terminal of the PGA gain amplifier by setting NMICPGA[1] address (0x2C) to HIGH. When the MIC- is used as a single ended input, MIC+ should be conned to VREF by setting PMICPGA[0] address (0x2C) bit to LOW. The AUX input signal can also be mixed with the MIC- input signal by setting AUXPGA[2] address (0x2C) to HIGH.

When the associated control bit NMICPGA[1] address 0X2C is set to logic = 0, the MIC- pin is connected to a resistor of approximately 30kΩ which is tied to VREF. The purpose of the tie to VREF is to reduce any pop or click sound by keeping the DC level of the MIC- pin close to VREF at all times. It is important for a system designer to know that the MIC-input impedance varies as a function of the selected PGA gain. This is normal and expected for a difference amplifier type topology. The above table gives the nominal resistive impedance values for this input over the possible gain range. Impedance for specific gain values not listed in this table can be estimated through interpolation between listed values.

### 12.1.2.3. PGA Gain Control

The PGA amplification is common to all three input pins MIC-, MIC+, AUX, and enabled by PGAEN[2] address (0x02). It has a range of -12dB to +35.25dB in 0.75dB steps, controlled by PGAGAIN[5:0] address (0x2D). Input PGA gain will not be used when ALC is enabled using ALCEN[8] address (0x20).

Addr	Bit 8	Bit 7	Bit 6	Bit 5	Bit 4	Bit 3	Bit 2	Bit 1	Bit 0	Default
0x2D	0	PGAZC	PGAMT	PGAGAIN[5:0]					0x010	
0x20	ALCEN	0	0	ALCMXGAIN[2:0]		ALCMNGAIN[2:0]			0x038	

Table 5: Registers associated with ALC and Input PGA Gain Control

### 12.1.3. PGA Boost Stage

The boost stage has three inputs connected to the PGA Boost Mixer. All three inputs can be individually connected or disconnected from the PGA Boost Mixer. The boost stage can be enabled by setting BSTEN[4] address (0x02) to HIGH. The following figure shows the PGA Boost stage.

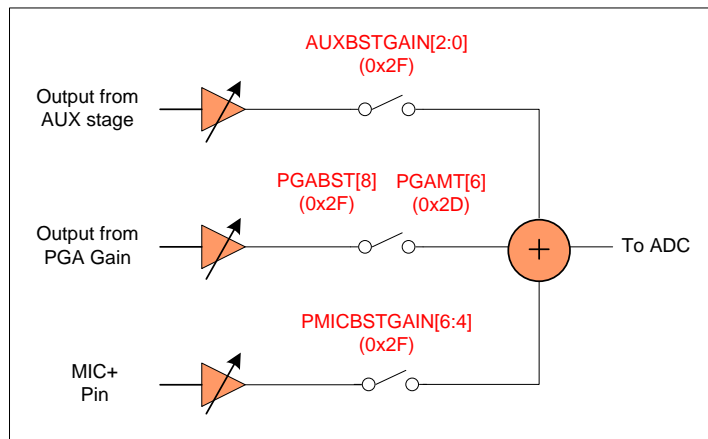

Figure 6: Boost Stage Block Diagram

The signal from AUX stage can be amplified at the PGA Boost stage before connecting to the Boost Mixer by setting a binary value from “001” – “111” to AUXBSTGAIN[2:0] address (0x2F). The path is disconnected by setting “000” to the AUXBSTGAIN bits.

Signal from PGA stage to the PGA Boost Mixer is disconnected or muted by setting PGAMT[6] address (0x2D) to HIGH. In this path the PGA boost can be a fixed value of +20dB or 0dB, controlled by the PGABST[8] address (0x2F) bit.

The signal from MIC+ pin to the PGA Boost Mixer is disconnected by setting ‘000’ binary value to PMICBSTGAIN[6:4] address (0x2F) and any other combination connects the path.

Bit(s)	Addr	Parameter	Programmable Range
BSTEN[4]	0x02	Enable PGA Boost Block	0 = Boost stage OFF 1 = Boost stage ON
PGAMT[6]	0x2D	Mute control for input PGA	0=Input PGA not muted 1=Input PGA muted
AUXBSTGAIN[2:0]	0x2F	Boost AUX signal	Range: -12dB to +6dB @ 3dB increment
PMICBSTGAIN[6:4]	0x2F	Boost MIC+ signal	Range: -12dB to +6dB @ 3dB increment
PGABST[8]	0x2F	Boost PGA stage	0 = PGA output has +0dB 1 = PGA output has +20dB

Table 6: Registers associated with PGA Boost Stage Control

## 12.2. MICROPHONE BIASING

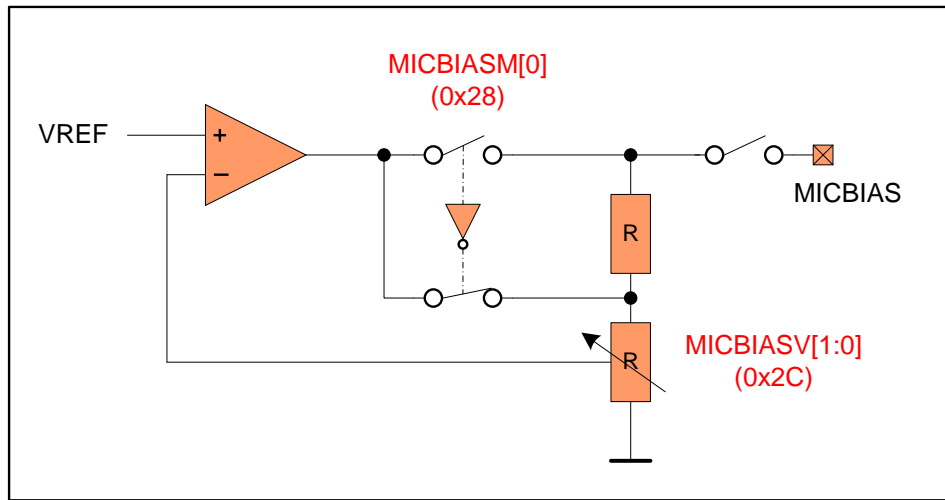

Figure 7: Microphone Bias Schematic

The MICBIAS pin is a low-noise microphone bias source for an external microphone, which can provide a maximum of 3mA of bias current. This DC bias voltage is suitable for powering either traditional ECM (electret) type microphones, or for MEMS types microphones with an independent power supply pin. Seven different bias voltages are available for optimum system performance, depending on the specific application. The microphone bias pin normally requires an external filtering capacitor as shown on the schematic in the Application section.

The output bias can be enabled by setting MICBIASEN[4] address (0x01) to HIGH. It has various voltage values selected by a combination of bits MICBIASM[4] address (0x3A) and MICBIASV[8:7] address (0x2C).

The low-noise feature results in greatly reduced noise in the external MICBIAS voltage by placing a resistor of approximately 200-ohms in series with the output pin. This creates a low pass filter in conjunction with the external microphone-bias filter capacitor, but without any additional external components.

Bit(s)	Addr	Parameter	Programmable Range
MICBIASEN[4]	0x01	Microphone bias enable	0 = Disable 1 = Enable
MICBIASM[4]	(0x3A)	Microphone bias mode selection	
MICBIASV[8:7]	(0x2C)	Microphone bias voltage selection	0 = Disable 1 = Enable

Table 7: Register associated with Microphone Bias

Below are the unloaded values when MICBIASM[4] is set to 1 and 0. When loaded, the series resistor will cause the voltage to drop, depending on the load current.

Microphone Bias Voltage Control			
MICBIASV[8:7]		MICBIASM[4] = 0	MICBIASM[4]= 1
0	0	0.9* VDDA	0.85* VDDA
0	1	0.65* VDDA	0.60* VDDA
1	0	0.75* VDDA	0.70* VDDA
1	1	0.50* VDDA	0.50* VDDA

Table 8: Microphone Bias Voltage Control

### 12.3. ADC DIGITAL FILTER BLOCK

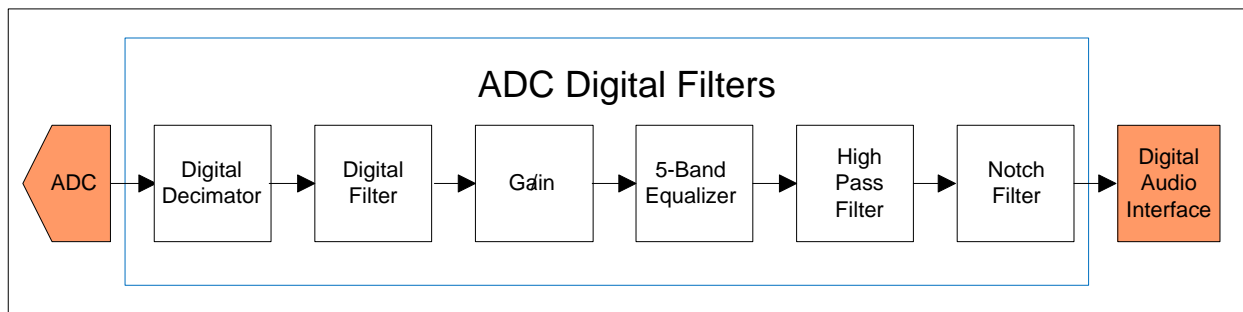

Figure 8: ADC Digital Filter Path Block Diagram

The ADC digital filter block performs a 24-bit signal processing. The block consists of an oversampled analog sigma-delta modulator, digital decimator, digital filter, 5-band graphic equalizer, high pass filter, and a notch filter. For digital decimator and 5-band graphic equalizer refer to “Output Signal Path”. The oversampled analog sigma-delta modulator provides a bit stream to the decimation stages and filter. The ADC coding scheme is in twos-complement format and the full-scale input level is proportional to VDDA. With a 3.3V supply voltage, the full-scale level is 1.0V<sub>RMS</sub> and any voltage greater than full scale may overload the ADC and cause distortion. The ADC is enabled by setting ADCEN[0] address (0x02) bit. Polarity and oversampling rate of the ADC output signal can be changed by ADCPL[0] address (0x0E) and ADCOS[3] address (0x0E) respectively.

Bit(s)	Addr	Parameter	Programmable Range
ADCPL[0]	0x0E	ADC Polarity	0 = Normal 1 = Inverted
ADCOS[3]	0x0E	ADC Over Sample Rate	0=64x (Lowest power) 1=128x (best SNR at typical condition)
HPFEN[8]	0x0E	High Pass Filter Enable	0 = Disable 1 = Enable
HPFAM[7]	0x0E	Audio or Application Mode	0 = Audio (1 <sup>st</sup> order, fc ~ 3.7 Hz) 1 = Application (2 <sup>nd</sup> order, fc =HPF)
HPF[6:4]	0x0E	High Pass Filter frequencies	82 Hz to 612 Hz dependant on the sample rate

ADCEN[0]	0x02	Enable ADC	0 = Disable 1 = Enable
SMPLR[3:1]	0x07	Sample rate	8k Hz to 48 kHz

Table 9: Register associated with ADC

### 12.3.1. Programmable High Pass Filter (HPF)

The high pass filter (HPF) has two different modes that it can operate in either Audio or Application mode HPFAM[7] address (0x0E). In Audio Mode (HPFAM=0) the filter is first order, with a cut-off frequency of 3.7Hz. In Application mode (HPFAM=1) the filter is second order, with a cut-off frequency selectable via the HPF[2:0] register bits. Cut-off frequency of the HPF depends on sample frequency selected by SMPLR[3:1] address (0x07). The HPF is enabled by setting HPFEN[8] address (0x0E) to HIGH. Table below shows the cut-off frequencies with different sampling rate.

HPF[2:0]	fs (kHz)								
	SMPLR=101/100			SMPLR=011/010			SMPLR=001/000		
	8	11.025	12	16	22.05	24	32	44.1	48
000	82	113	122	82	113	122	82	113	122
001	102	141	153	102	141	153	102	141	153
010	131	180	156	131	180	156	131	180	156
011	163	225	245	163	225	245	163	225	245
100	204	281	306	204	281	306	204	281	306
101	261	360	392	261	360	392	261	360	392
110	327	450	490	327	450	490	327	450	490
111	408	563	612	408	563	612	408	563	612

Table 10: High Pass Filter Cut-off Frequencies (HPFAM=1)

### 12.3.2. Programmable Notch Filter (NF)

The NAU88C14 has a programmable notch filter where it passes all frequencies except those in a stop band centered on a given center frequency. The filter gives lower distortion and flattens response. The notch filter is enabled by setting NFCEN[7] address (0x1B) to HIGH. The variable center frequency is programmed by setting two's complement values to NFCA0[6:0] address (0x1C), NFCA0[13:7] address (0x1B) and NFCA1[6:0] address (0x1E), NFCA1[13:7] address (0x1D) registers. The coefficients are updated in the circuit when the NFCU[8] bit is set HIGH in a write to any of the registers NF1-NF4 address (0x1B, 0x1C, 0x1D, 0x1E).

Addr	Bit 8	Bit 7	Bit 6	Bit 5	Bit 4	Bit 3	Bit 2	Bit 1	Bit 0	Default
0x1B	NFCU	NFCEN	NFCA0[13:7]							0x000
0x1C	NFCU	0	NFCA0[6:0]							0x000
0x1D	NFCU	0	NFCA1[13:7]							0x000
0x1E	NFCU	0	NFCA1[6:0]							0x000

Table 11: Registers associated with Notch Filter Function



	$A_0$	$A_1$	Notation	Register Value (DEC)
<b>Coefficient</b>	$\frac{1 - \tan\left(\frac{2\pi f_b}{2f_s}\right)}{1 + \tan\left(\frac{2\pi f_b}{2f_s}\right)}$	$-(1 + A_0) \times \cos\left(\frac{2\pi f_c}{f_s}\right)$	$f_c$ = center frequency (Hz) $f_b$ = -3dB bandwidth (Hz) $f_s$ = sample frequency (Hz)	NFCA0 = $-A_0 \times 2^{13}$ NFCA1 = $-A_1 \times 2^{12}$ (then convert to 2's complement)

Table 12: Equations to Calculate Notch Filter Coefficients

### 12.3.3. Digital ADC Gain Control

The digital ADC can be muted by setting “0000 0000” to ADCGAIN[7:0] address (0x0F). Any other combination digitally attenuates the ADC output signal in the range -127dB to 0dB in 0.5dB increments].

Addr	Name	Bit 8	Bit 7	Bit 6	Bit5	Bit 4	Bit 3	Bit 2	Bit 1	Bit 0	Default
0x0F	ADCG	0	ADCGAIN								0x0FF

Table 13: Register associated with ADC Gain

## 12.4. PROGRAMMABLE GAIN AMPLIFIER (PGA)

NAU88C14 has a programmable gain amplifier (PGA) which controls the gain such that the signal level of the PGA remains substantially constant as the input signal level varies within a specified dynamic range. The PGA has two functions

- Automatic level control (ALC) or
- Input peak limiter

The Automatic Level Control (ALC) seeks to control the PGA gain in response to the amplitude of the input signal such that the PGA output maintains a constant envelope. A digital peak detector monitors the input signal amplitude and compares it to a register defined threshold level ALCSL[3:0] address (0x21). Note: When the ALC automatic level control is enabled, the function of the ALC is to automatically adjust PGAGAIN[5:0] address (0x2D) volume setting.

### 12.4.1. Automatic level control (ALC)

The ALC seeks to control the PGA gain such that the PGA output maintains a constant envelope. This helps to prevent clipping at the input of the sigma delta ADC while maximizing the full dynamic range of the ADC. The ALC monitors the output of the ADC, measured after the digital decimator has converted it to 1.23 fixed-point formats. The ADC output is fed into a peak detector, which updates the measured peak value whenever the absolute value of the input signal is higher than the current measured peak. The measured peak gradually decays to zero unless a new peak is detected, allowing for an accurate measurement of the signal envelope. Based on a comparison between the measured peak value and the target value, the ALC block adjusts the gain control, which is fed back to the PGA.

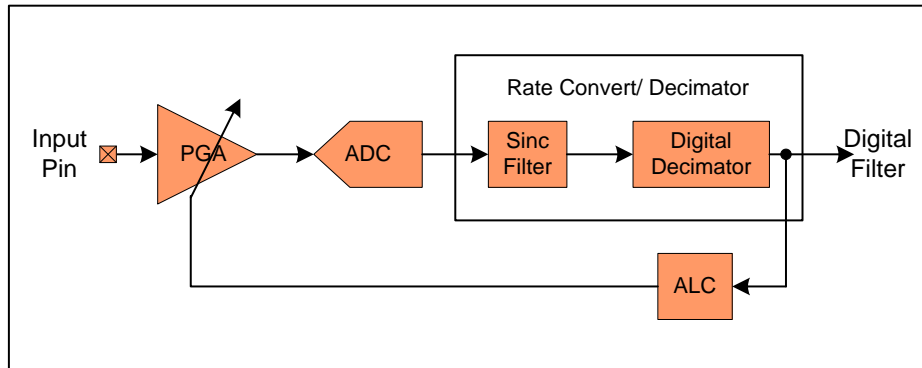

Figure 9: ALC Block Diagram

The ALC is enabled by setting ALCEN[8] address (0x20) bit to HIGH. The ALC has two functional modes, which is set by ALCM[8] address (0x22).

- Normal mode (ALCM = LOW)
- Peak Limiter mode (ALCM = HIGH)

When the ALC is disabled, the input PGA remains at the last controlled value of the ALC. An input gain update must be made by writing to the PGAGAIN[5:0] address (0x2D). A digital peak detector monitors the input signal amplitude and compares it to a register defined threshold level ALCSL[3:0] address (0x21).

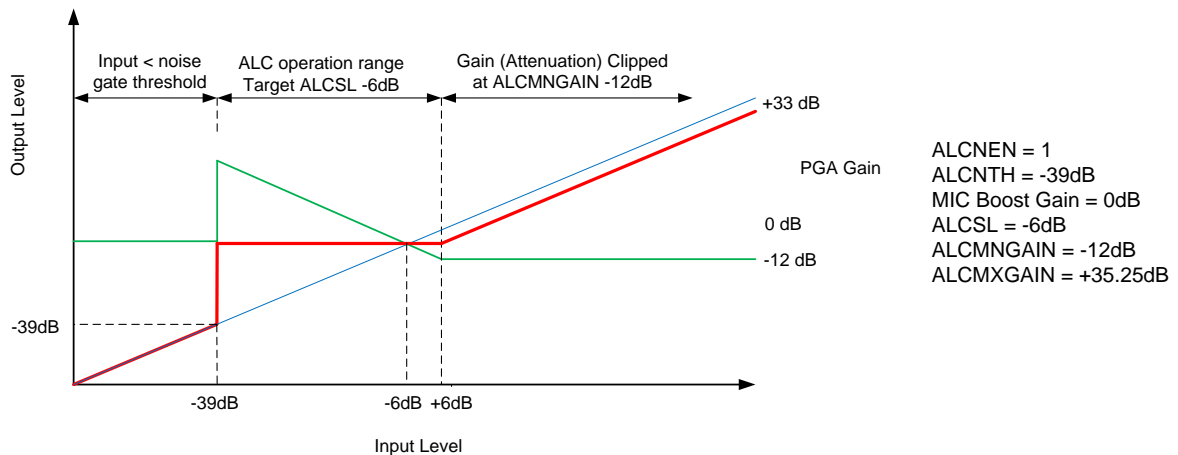

Figure 10: ALC Response Graph

The registers listed in the following section allow configuration of ALC operation with respect to:

- ALC target level
- Gain increment and decrement rates
- Minimum and maximum PGA gain values for ALC operating range

- Hold time before gain increments in response to input signal
- Inhibition of gain increment during noise inputs
- Limiter mode operation

Bit(s)	Addr	Parameter	Programmable Range
ALCMNGAIN[2:0]	0x20	Minimum Gain of PGA	Range: -12dB to +30dB @ 6dB increment
ALCMXGAIN[2:0]		Maximum Gain of PGA	Range: -6.75dB to +35.25dB @ 6dB increment
ALCEN[8]		Enable ALC function	0 = Disable 1 = Enable
ALCSL[3:0]	0x21	ALC Target	Range: -28.5dB to -6dB @ 1.5dB increment
ALCHT[3:0]		ALC Hold Time	Range: 0ms to 1s, time doubles with every step)
ALCZC[8]		ALC Zero Crossing	0 = Disable 1 = Enable
ALCATK[3:0]	0x22	ALC Attack time	ALCM=0 – Range: 125us to 128ms ALCM=1 – Range: 31us to 32ms (time doubles with every step)
ALCDCY[3:0]		ALC Decay time	ALCM=0 – Range: 500us to 512ms ALCM=1 – Range: 125us to 128ms (Both ALC time doubles with every step)
ALCM[8]		ALC Select	0 = ALC mode 1 = Limiter mode

Table 14: Registers associated with ALC Control

The operating range of the ALC is set by ALCMXGAIN[5:3] address (0x20) and ALCMNGAIN[2:0] address (0x20) bits such that the PGA gain generated by the ALC is between the programmed minimum and maximum levels. When the ALC is enabled, the PGA gain is disabled.

In Normal mode, the ALCMXGAIN bits set the maximum level for the PGA in the ALC mode but in the Limiter mode ALCMXGAIN has no effect because the maximum level is set by the initial PGA gain setting upon enabling of the ALC.

ALCMAXGAIN	Maximum Gain (dB)	ALCMINGAIN	Minimum Gain (dB)
111	35.25	000	-12
110	29.25	001	-6
ALC Max Gain Range 35.25dB to -6dB @ 6dB increments		ALC Min Gain Range -12dB to 30dB @ 6dB increments	
001	-0.75	110	24
000	-6.75	111	30

Table 15: ALC Maximum and Minimum Gain Values

**12.4.1.1. Normal Mode**

Normal mode is selected when ALCM[8] address (0x22) is set LOW and the ALC is enabled by setting ALCEN[8] address (0x20) HIGH. This block adjusts the PGA gain setting up and down in response to the input level. A peak detector circuit measures the envelope of the input signal and compares it to the target level set by ALCSL[3:0] address (0x21). The ALC decreases the gain when the measured envelope is greater than the target and increases the gain when the measured envelope is less than  $-1.5\text{dB}$ . The following waveform illustrates the behavior of the ALC.

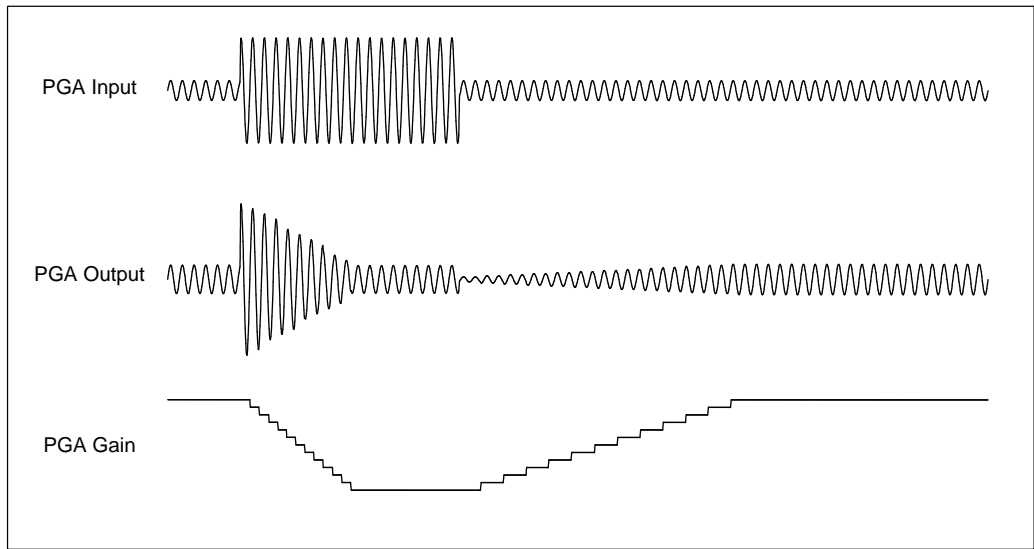

Figure 11: ALC Normal Mode Operation

**12.4.1.2. ALC Hold Time (Normal mode Only)**

The hold parameter ALCHT[3:0] configures the time between detection of the input signal envelope being outside of the target range and the actual gain increase.

Input signals with different characteristics (e.g., voice vs. music) may require different settings for this parameter for optimal performance. Increasing the ALC hold time prevents the ALC from reacting too quickly to brief periods of silence such as those that may appear in music recordings; having a shorter hold time, on the other hand, may be useful in voice applications where a faster reaction time helps to adjust the volume setting for speakers with different volumes. The waveform below shows the operation of the ALCHT parameter.

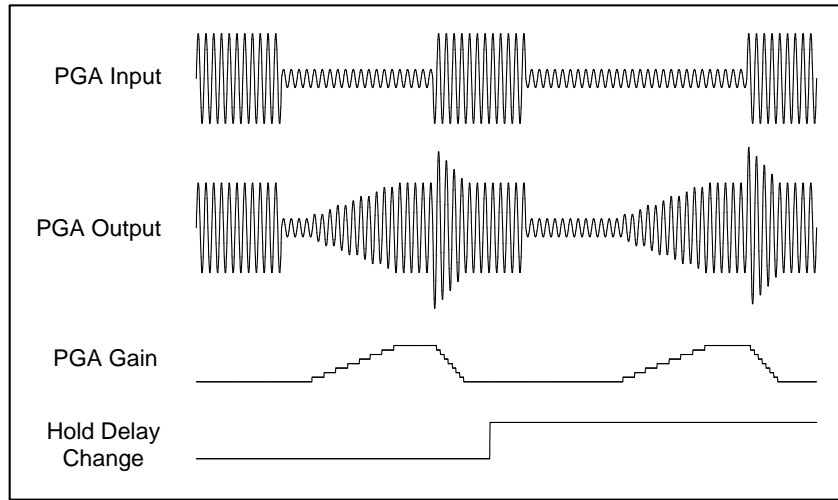

Figure 12: ALC Hold Time

**12.4.2. Peak Limiter Mode**

Peak Limiter mode is selected when ALCM[8] address (0x22) is set to HIGH and the ALC is enabled by setting ALCEN[8] address (0x20). In limiter mode, the PGA gain is constrained to be less than or equal to the gain setting at the time the limiter mode is enabled. In addition, attack and decay times are faster in limiter mode than in normal mode as indicated by the different lookup tables for these parameters for limiter mode. The following waveform illustrates the behavior of the ALC in Limiter mode in response to changes in various ALC parameters.

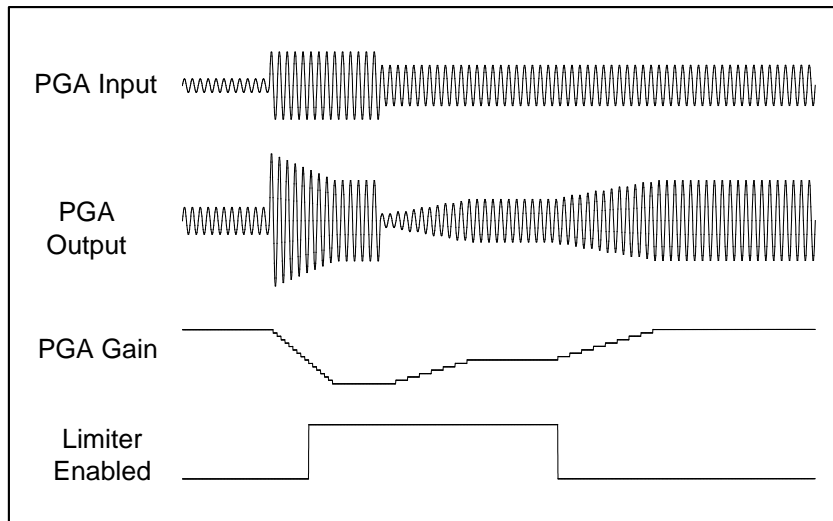

Figure 13: ALC Limiter Mode Operations

When the input signal exceeds 87.5% of full scale, the ALC block ramps down the PGA gain at the maximum attack rate (ALCATK=0000) regardless of the mode and attack rate settings until the ADC output level has been reduced below the threshold. This limits ADC clipping if there is a sudden increase in the input signal level.

### 12.4.3. Attack Time

When the absolute value of the ADC output exceeds the level set by the ALC threshold, ALC $SL[3:0]$  address (0x21), attack mode is initiated at a rate controlled by the attack rate register ALC $ATK[3:0]$  address (0x22). The peak detector in the ALC block loads the ADC output value when the absolute value of the ADC output exceeds the current measured peak; otherwise, the peak decays towards zero, until a new peak has been identified. This sequence is continuously running. If the peak is ever below the target threshold, then there is no gain decrease at the next attack timer time; if it is ever above the target-1.5dB, then there is no gain increase at the next decay timer time.

### 12.4.4. Decay Times

The decay time ALC $DCY[6:4]$  address (0x22) is the time constant used when the gain is increasing. In limiter mode, the time constants are faster than in ALC mode.

### 12.4.5. Noise gate (normal mode only)

A noise gate is used when there is no input signal or the noise level is below the noise gate threshold. The noise gate is enabled by setting ALC $NEN[3]$  address (0x23) to HIGH. It does not remove noise from the signal. The noise gate threshold ALC $NTH[2:0]$  address (0x23) is set to a desired level so when there is no signal or a very quiet signal (pause), which is composed mostly of noise, the ALC holds the gain constant instead of amplifying the signal towards the target threshold. The noise gate only operates in conjunction with the ALC and ONLY in Normal mode. The noise gate flag is asserted when

$$(\text{Signal at ADC} - \text{PGA gain} - \text{MIC Boost gain}) < \text{ALCNTH (ALC Noise Gate Threshold) (dB)}$$

Levels at the extremes of the range may cause inappropriate operation, so care should be taken when setting up the function.

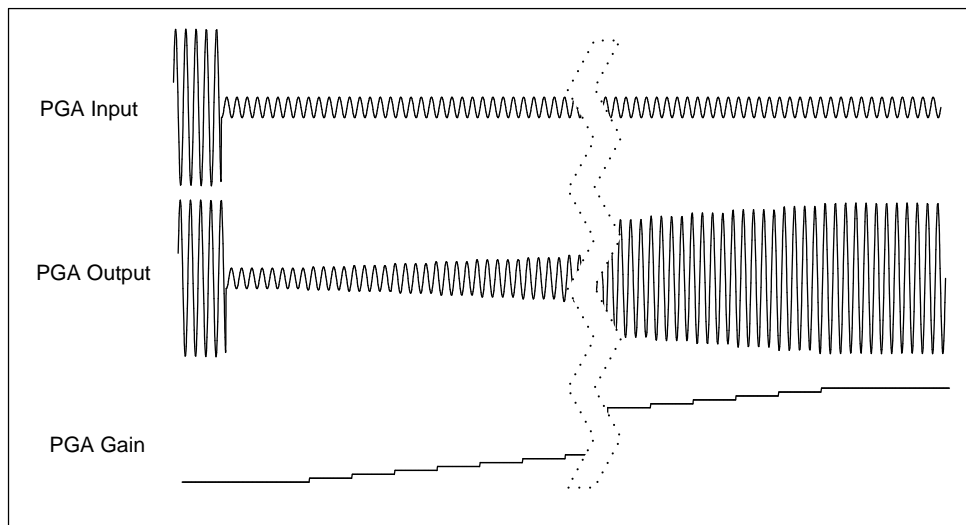

Figure 14: ALC Operation with Noise Gate disabled

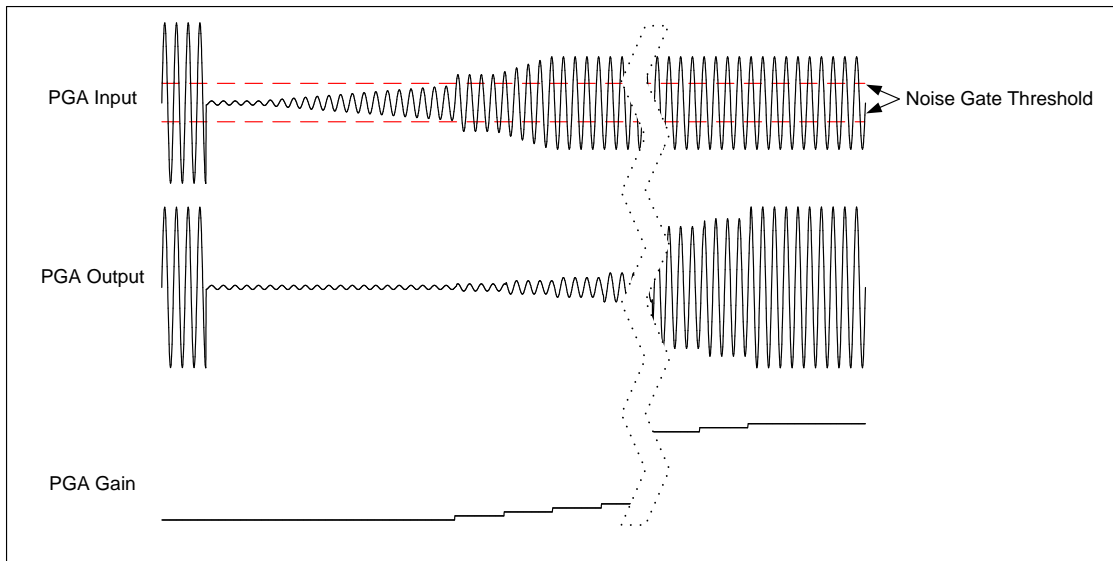

Figure 15: ALC Operation with Noise Gate Enabled

#### 12.4.6. Zero Crossing

The PGA gain comes from either the ALC block when it is enabled or from the PGA gain register setting when the ALC is disabled. Zero crossing detection may be enabled to cause PGA gain changes to occur only at an input zero crossing. Enabling zero crossing detection limits clicks and pops that may occur if the gain changes while the input signal has a high volume.

There are two zero crossing detection enables:

- Register ALCZC[8] address (0x21) – is only relevant when the ALC is enabled.
- Register PGAZC[7] address (0x2D) – is only relevant when the ALC is disabled.

If the zero crossing function is enabled (using either register) and SCLKEN[0] address (0x07) is asserted, the zero cross timeout function may take effect. If the zero crossing flag does not change polarity within 0.25 seconds of a PGA gain update (either via ALC update or PGA gain register update), then the gain will update. This backup system prevents the gain from locking up if the input signal has a small swing and a DC offset that prevents the zero crossing flag from toggling.

## 12.5. DAC DIGITAL FILTER BLOCK

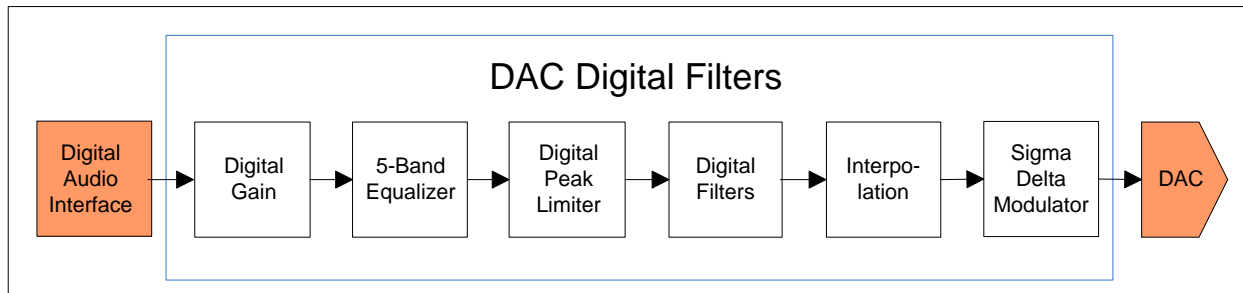

Figure 16: DAC Digital Filter Path

The DAC digital block uses 24-bit signal processing to generate analog audio with a 16-bit digital sample stream input. This block consists of a sigma-delta modulator, 5-band graphic equalizer, high pass filter, digital gain/filters, de-emphasis, and analog mixers. The DAC coding scheme is in twos complement format and the full-scale output level is proportional to  $V_{DDA}$ . With a 3.3V supply voltage, the full-scale output level is  $1.0V_{RMS}$ . The DAC is enabled by setting  $DACEN[0]$  address (0x03) bit HIGH.

Bit(s)	Addr	Parameter	Programmable Range
DACEN[0]	0x03	DAC enable	0 = Disable 1 = Enable
ADDAP[0]	0x05	Pass-through of ADC output data into DAC input	0 = Disable 1 = Enable
DACPL[0]	0x0A	DAC Polarity	0 = No Inversion 1 = DAC Output Inverted
AUTOMT[2]		Auto Mute	0 = Disable 1 = Enable
DEEMP[5:4]		Sample Rate	32 kHz, 44.1 kHz, and 48 kHz
DACMT[6]		Soft Mute	0 = Disable 1 = Enable
DACGAIN[7:0]	0x0B	DAC Volume Control	Range: -127dB to 0dB @ 0.5dB increment, 00 hex is Muted
DACLIMATK[3:0]	0x18	DAC Limiter Attack	Range: 68us to 139ms
DACLIMDCY[7:4]		DAC Limiter Decay	Range: 544us to 1.1s
DACLIMEN[8]		DAC Limiter Enable	0 = Disable 1 = Enable
DACLIMBST[3:0]	0x19	DAC Limiter Volume Boost	Range: 0dB to +12dB @ 1dB increment
DACLIMTHL[6:4]		DAC Limiter Threshold	Range: -6dB to -1bB @ 1dB increment

Table 16: Registers associated with DAC Gain Control



### 12.5.1. DAC Soft Mute

The NAU88C14 also has a Soft Mute function, which gradually attenuates the volume of the digital signal to zero. When removed, the gain will ramp back up to the digital gain setting. This function is disabled by default. This feature provides a tool that is useful for using the DACs without introducing pop and click sounds. To play back an audio signal, it must first be disabled by setting the DACMT[6] address (0x0A) bit to LOW.

### 12.5.2. DAC Auto Mute

The output of the DAC can be muted by the analog auto mute function. The auto mute function is enabled by setting AUTOMT[2] address (0x0A) to HIGH and applied to the DAC output when it sees 1024 consecutive zeros at its input. If at any time there is a non-zero sample value, the DAC will be un-muted, and the 1024 count will be reinitialized to zero.

### 12.5.3. DAC Sampling / Oversampling rate, Polarity, DAC Volume control and Digital Pass-through

The sampling rate of the DAC is determined entirely by the frequency of its input clock and the oversampling rate setting. The oversampling rate of the DAC can be changed to 64x or 128x. In the 128x oversampling mode it gives an improved audio performance at slightly higher power consumption. Because the additional supply current is only 1mA, in most applications the 128x oversampling is preferred for maximum audio performance.

The polarity of the DAC output signal can be changed as a feature sometimes useful in management of the audio phase. This feature can help minimize any audio processing that may be otherwise required as the data are passed to other stages in the system.

The effective output audio volume of the DAC can be changed using the digital volume control feature. This processes the output of the DAC to scale the output by the amount indicated in the volume register setting. Included is a “digital mute” value which will completely mute the signal output of the DAC. The digital volume setting can range from 0dB through -127dB in 0.5dB steps.

Digital audio pass-through allows the output of the ADC to be directly sent to the DAC as the input signal to the DAC for DAC output. In this mode of operation, the external digital audio signal for the DAC will be ignored. The pass-through function is useful for many test and application purposes, and the DAC output may be utilized in any way that is normally supported for the DAC analog output signals.

### 12.5.4. Hi-Fi DAC De-Emphasis and Gain Control

The NAU88C14 has Hi-Fi DAC gain control for signal conditioning. The level of attenuation for an eight-bit code X is given by:

	$0.5 \times (X-255)$ dB	for $1 \leq X \leq 255$ ;	MUTE for $X = 0$
--	-------------------------	---------------------------	------------------

It includes on-chip digital de-emphasis and is available for sample rates of 32 kHz, 44.1 kHz, and 48 kHz. The digital de-emphasis can be enabled by setting DEEMP[5:4] address (0x0A) bits depending on the input sample rate. The de-emphasis feature is included to accommodate audio recordings that utilize 50/15  $\mu$ s pre-emphasis equalization as a

means of noise reduction. The DAC output can be inverted (phase inversion) by setting DACPL[1:0] address (0x0A) to HIGH, non-inverted output is set by default.

### 12.5.5. Digital DAC Output Peak Limiter

Output Peak-Limiters reduce the dynamic range by ensuring the signal will not exceed a certain threshold, while maximizing the RMS of the resulted audio signal, and minimizing audible distortions. NAU88C14 has a digital output limiter function. The operation of this is shown in figure below. In this diagram the upper graph shows the envelope of the input/output signals and the lower graph shows the gain characteristic. The limiter has a programmable threshold, DACLIMTHL[6:4] address (0x19), which ranges from -1dB to -6dB in 1dB increments. The digital peak limiter seeks to keep the envelope of the output signal within the target threshold +/- 0.5dB. The attack and decay rates programmed in registers DACLIMATK[3:0] address (0x18) and DACLIMDCY[7:4] address (0x18) specify how fast the digital peak limiter decrease and increase the gain, respectively, in response to the envelope of the output signal falling outside of this range. In normal operation LIMBST=000 signals below this threshold are unaffected by the limiter.

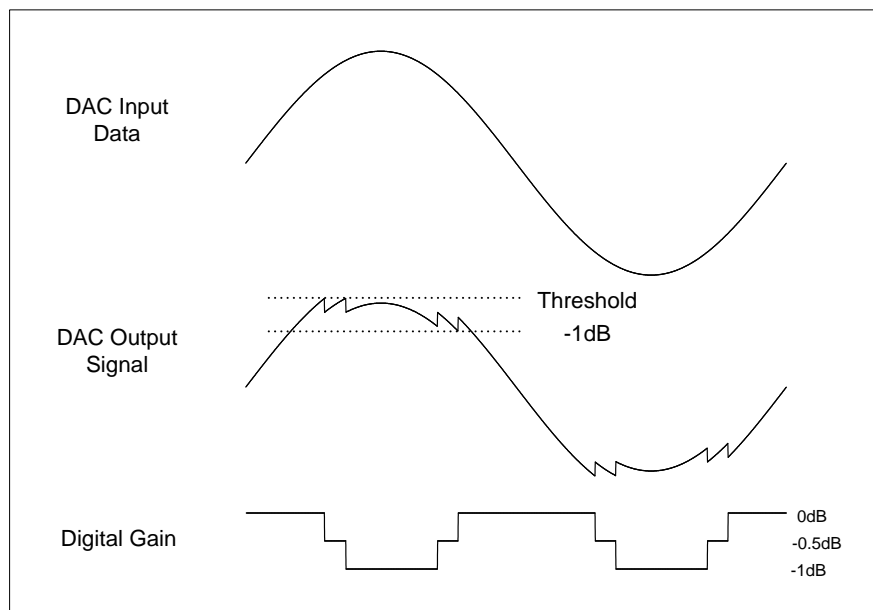

Figure 17: DAC Digital Limiter Control

### 12.5.6. Volume Boost

The limiter has programmable upper gain, which boosts signals below the threshold to compress the dynamic range of the signal and increase its perceived loudness. This operates as an ALC function with limited boost capability. The volume boost is from 0dB to +12dB in 1dB steps, controlled by the DACLIMBST[3:0] register bits. The output limiter volume boost can also be used as a stand-alone digital gain boost when the limiter is disabled.

### 12.5.7. 5-Band Equalizer

NAU88C14 features 5-band graphic equalizer with low distortion, low noise, and wide dynamic range, and is an ideal choice for Hi-Fi applications. All five bands are fully parametric with independently adjustable bandwidth that displays exceptional tonal qualities. Each of the five bands offers +/- 12dB of boost and cut with 1dB resolution. The five bands are divided in to three sections Low, Mid and High bands. The High and the Low bands are shelving filters and the mid three are peak filters. The equalizer can be applied to the ADC or DAC path under control of the EQM[8] address (0x12) register bit.

Bit(s)	Address	Parameter	Programmable Range
EQM[8]	0x12	Equalizer Enable	
EQ1CF[6:5]		Band 1 Cut-off Frequency	Range: 80 Hz to 175 Hz
EQ1GC[4:0]		Band 1 Gain Control	Range: -12 dB to +12 dB @ 1.0dB increment
EQ2BW[8]	0x13	Band 2 Equalizer Bandwidth	Narrow or Wide
EQ2CF[6:5]		Band 2 Centre Frequency	Range: 230 Hz to 500 Hz
EQ2GC[4:0]		Band 2 Gain Control	Range: -12 dB to +12 dB @ 1.0dB increment
EQ2BW[8]	0x14	Band 3 Equalizer Bandwidth	Narrow or Wide
EQ3CF[6:5]		Band 3 Centre Frequency	Range: 650 Hz to 1.4 kHz
EQ3GC[4:0]		Band 3 Gain Control	Range: -12 dB to +12 dB @ 1.0dB increment
EQ4BW[8]	0x15	Band 4 Equalizer Bandwidth	Narrow or Wide
EQ4CF[6:5]		Band 4 Centre Frequency	Range: 1.8 kHz to 4.1 kHz
EQ4GC[4:0]		Band 4 Gain Control	Range: -12 dB to +12 dB @ 1.0dB increment
EQ5CF[6:5]	0x16	Band 5 Cut-off Frequency	Range: 5.3 kHz to 11.7 kHz
EQ5GC[4:0]		Band 5 Gain Control	Range: -12 dB to +12 dB @ 1.0dB increment

Table 17: Registers associated with Equalizer Control

## 12.6. ANALOG OUTPUTS

The NAU88C14 features two different types of outputs, a single-ended MONO output (MOUT) and a differential speaker outputs (SPKOUT+ and SPKOUT-). The speaker amplifiers designed to drive a load differentially; a configuration referred to as Bridge-Tied Load (BTL).

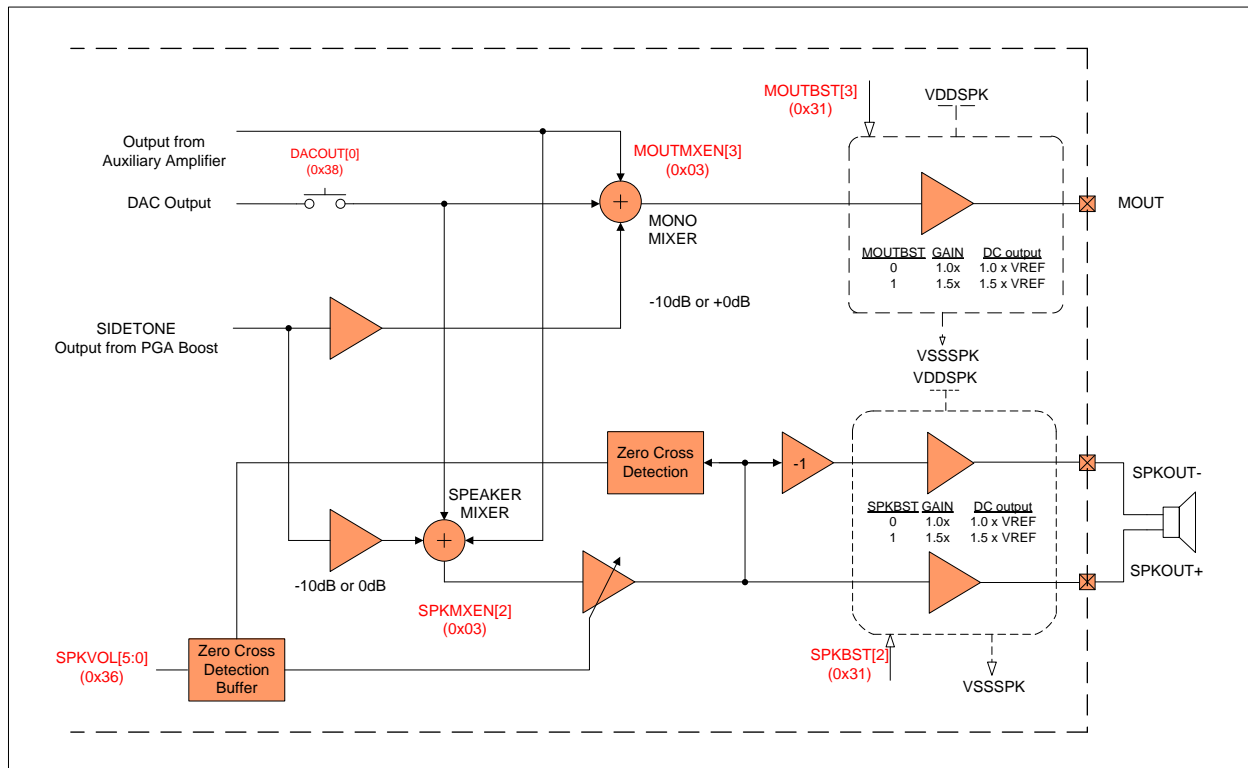

Figure 18: Speaker and MONO Analogue Outputs

**Important:** For analog outputs de-popping purpose, when powering up speakers, headphone, AUXOUTs, certain delays are generated after enabling sequence. However, the delays are created by MCLK and sample rate register. For correct operation, sending I2S signal no earlier than 250ms after speaker or headphone enabled and MCLK appearing.

### 12.6.1. Speaker Mixer Outputs

The speaker amplifiers are designed to drive a load differentially; a configuration referred to as Bridge-Tied Load (BTL). The differential speaker outputs can drive a single 8Ω speaker or two headphone loads of 16Ω or 32Ω or a line output. Driving the load differentially doubles the output voltage. The output of the speaker can be manipulated by changing attenuation and the volume (loudness of the output signal).

The output stage is powered by the speaker supply, VDDSPK, which are capable of driving up to 1.5V<sub>RMS</sub> signals (equivalent to 3V<sub>RMS</sub> into a BTL speaker). The speaker outputs can be controlled and can be muted individually. The output pins are at reference DC level when the output is muted.

Bit(s)	Addr	Parameter	Programmable Range
SPKMXEN[2]	0x03	Speaker Mixer enable	0 – Disabled 1 – Enabled
PSPKEN[5]	0x03	Speaker positive terminal enable	0 – Disabled 1 – Enabled
NSPKEN[6]	0x03	Speaker negative terminal enable	0 – Disabled 1 – Enabled
SPKATT[1]	0x28	Speaker output attenuation	0 – 0dB 1 - -10dB
SPKBST[2]	0x31	Speaker output Boost	0 – (1.0x VREF) Boost 1- (1.5 x VREF) Boost
SPKGAIN[5:0]	0x36	Speaker output Volume	Range: -57dB to +6dB @ 6dB increment
SPKMT[6]	0x36	Speaker output Mute	0 – Speaker Enabled 1 – Speaker Muted

Table 18: Speaker Output Controls

### 12.6.2. MONO Mixer Output

The single ended output can drive headphone loads of 16Ω or 32Ω or a line output. The MOUT can be manipulated by changing attenuation and the volume (loudness of the output signal).

The output stage is powered by the speaker supply, VDDSPK, which are capable of driving up to 1.5V<sub>RMS</sub> signals. The MONO output can be enabled for signal output or muted. The output pins are at reference DC level when the output is muted.

Bit(s)	Addr	Parameter	Programmable Range
MOUTMXEN[3]	0x03	MONO mixer enable	0 – Disabled 1 – Enabled
MOUTEN[7]	0x03	MONO output enable	0 – Disabled 1 – Enabled
MOUTATT[2]	0x28	MONO output attenuation	0 – 0dB 1 - -10dB
MOUTBST[3]	0x31	MONO output boost	0 – (1.0x VREF) Boost 1- (1.5 x VREF) Boost
MOUTMXMT[6]	0x38	MONO Output Mixer Mute	0 – MONO Mixer Normal Mode 1 – MONO Mixer Muted
MOUTMT[4]	0x45	MONO Output Mute	0 – MONO Output Normal Mode 1 – MONO Output Muted

Table 19: MONO Output Controls

## 12.6.3. Unused Analog I/O

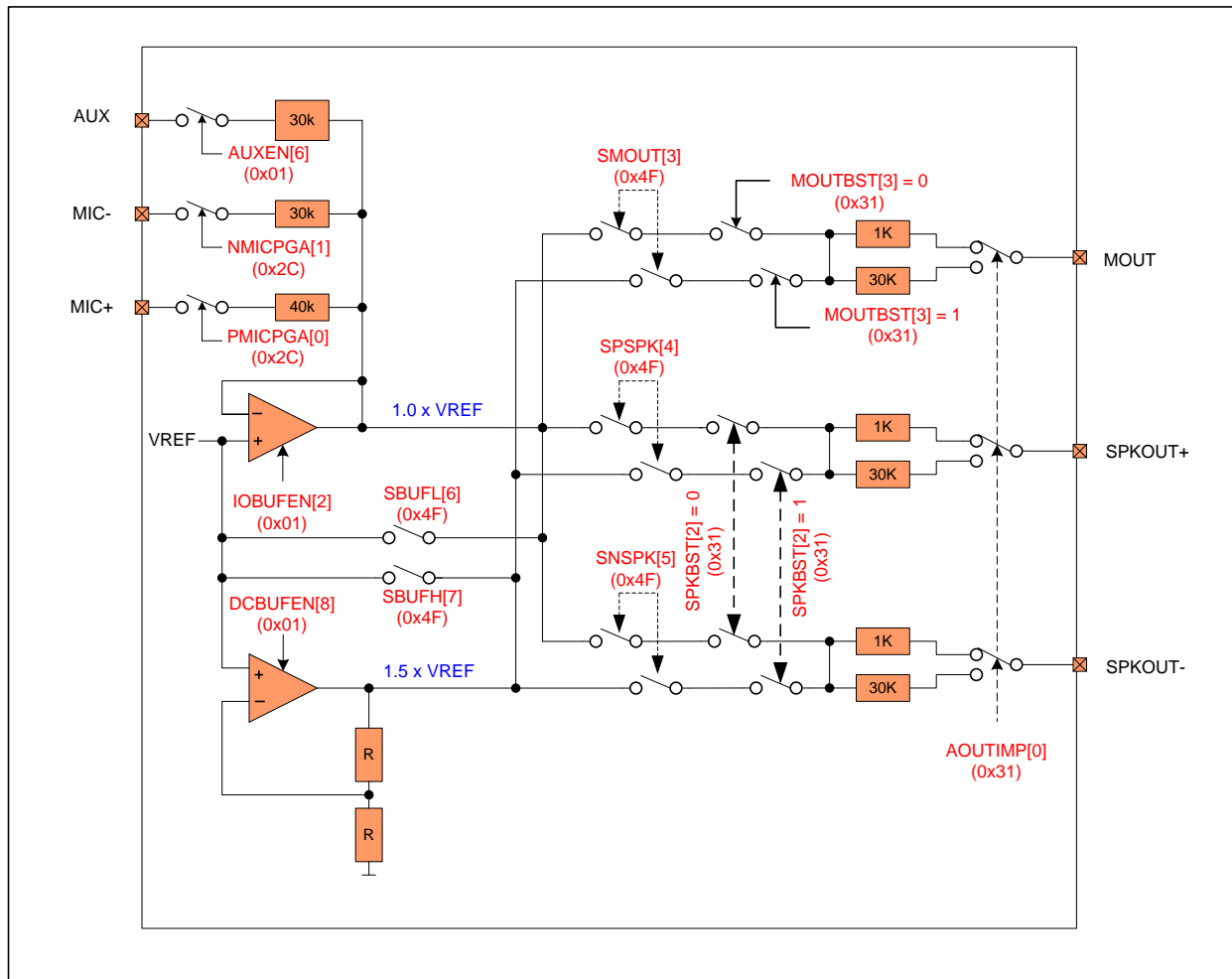

Figure 19: Tie-off Options for the Speaker and MONO output Pins

In audio and voice systems, any time there is a sudden change in voltage to an audio signal, an audible pop or click sound may be the result. Systems that change inputs and output configurations dynamically, or which are required to manage low power operation, need special attention to possible pop and click situations. The NAU88C14 includes many features which may be used to greatly reduce or eliminate pop and click sounds. The most common cause of a pop or click signal is a sudden change to an input or output voltage. This may happen in either a DC coupled system, or in an AC coupled system.

The strategy to control pops and clicks is similar for either a DC coupled system, or an AC coupled system. The case of the AC coupled system is the most common and the more difficult situation, and therefore, the AC coupled case will be the focus for this information section. When an input or output pin is being used, the DC level of that pin will be very close to half of the VDDA voltage that is present on the VREF pin. The only exception is that when outputs are operated in the 5-Volt mode known as the 1.5x boost condition, then the DC level for those outputs will be equal to 1.5xVREF. In all cases, any input or output capacitors will become charged to the operating voltage of the used input or output pin.

The goal to reduce pops and clicks is to insure that the charge voltage on these capacitors does not change suddenly at any time.

When an input or output is in a not-used operating condition, it is desirable to keep the DC voltage on that pin at the same voltage level as the DC level of the used operating condition. This is accomplished using special internal DC voltage sources that are at the required DC values. When an input or output is in the not-used condition, it is connected to the correct internal DC voltage as not to have a pop or click. This type of connection is known as a “tie-off” condition.

Two internal DC voltage sources are provided for making tie-off connections. One DC level is equal to the VREF voltage value, and the other DC level is equal to 1.5x the VREF value. All inputs are always tied off to the VREF voltage value. Outputs will automatically be tied to either the VREF voltage value or to the 1.5xVREF value, depending on the value of the “boost” control bit for that output. That is to say, when an output is set to the 1.5x gain condition, then that same output will automatically use the 1.5xVREF value for tie-off in the not-used condition. The input pull-ups are connected to IOBUFEN[2] address (0x01) buffer with a voltage source (VREF). The output pull-ups can be connected two different buffers depending on the voltage source. IOBUFEN[2] address (0x01) buffer is enabled if the voltage source is (VREF) and DCBUFEN[8] address (0x01) buffer is enabled if the voltage source is (1.5 x VREF). IOBUFEN[2] address (0x01) buffer is shared between input and output pins.

To conserve power, these internal voltage buffers may be enabled/disabled using control register settings. To better manage pops and clicks, there is a choice of impedance of the tie-off connection for unused outputs. The nominal values for this choice are 1k $\Omega$  and 30k $\Omega$ . The low impedance value will better maintain the desired DC level in the case when there is some leakage on the output capacitor or some DC resistance to ground at the NAU88C14 output pin. A tradeoff in using the low-impedance value is primarily that output capacitors could change more suddenly during power-on and power-off changes.

Automatic internal logic determines whether an input or output pin is in the used or un-used condition. This logic function is always active. An output is determined to be in the un-used condition when it is in the disabled unpowered condition, as determined by the power management registers. An input is determined to be in the un-used condition when all internal switches connected to that input are in the “open” condition.

## 12.7. GENERAL PURPOSE I/O

The CSb/GPIO pin can be configured in two ways, chip select for SPI interface and general purpose GPIO. Therefore, the general-purpose configuration is only available in the 2-Wire interface mode, which is configured by setting GPIOSEL[2:0] address (0x08) to 001 – 101. “000” configures the pin to be a chip select for SPI mode. The CSb/GPIO pin is not available in the SPI interface mode. When the pin is configured as an input, it can be used as chip select signal for SPI interface or for jack detect. When the pin is configured as output, it can be used for signaling analog mute, temperature alert, PLL frequency output, and PLL frequency lock. The CSb/GPIO pin can also output the master clock through a PLL or directly. The path also included a divider for different clocks needed in the system. Note that SCLKEN must be enabled when using the Jack Detect function.

Addr	D8	D7	D6	D5	D4	D3	D2	D1	D0	Default
0x08	0	0	0	GPIOPLL[1:0]		GPIOPL	GPIOSEL[2:0]			0x000
0x07	0	0	0	0	0	SMPLR[2:0]			SCLKEN	0x000

Table 20: General Purpose Control

### 12.7.1. Slow Timer Clock

An internal Slow Timer Clock is supplied to automatically control features that happen over a relatively long period of time, or time-spans. This enables the NAU88C14 to implement long time-span features without any host/processor management or intervention.

The Slow Timer Clock supports two features automatic time out for the zero-crossing holdoff of PGA volume changes, and timing for debouncing of the mechanical jack detection feature. If either feature is required, the Slow Timer Clock must be enabled. The Slow Timer Clock is initialized in the disabled state.

The Slow Timer Clock rate is derived from MCLK using an integer divider that is compensated for the sample rate as indicated by the register address (0x07). If the sample rate register value precisely matches the actual sample rate, then the internal Slow Timer Clock rate will be a constant value of 128ms. If the actual sample rate is, for example, 44.1kHz and the sample rate selected in register 0x07 is 48kHz, the rate of the Slow Timer Clock will be approximately 10% slower in direct proportion of the actual vs. indicated sample rate. This scale of difference should not be important in relation to the dedicated end uses of the Slow Timer Clock.

### 12.7.2. Jack Detect

Jack detect is a specific GPIO function. Jack detect is only available in 2-Wire mode only. Jack detect is selected by setting GPIOSEL[2:0] address (0x08) to "001". The GPIOPL[3] bit address (0x08) inverts the CSb/GPIO pin when set to 1. The table below shows all the combinations for jack insert detects.

The CSb/GPIO pin has an internal de-bounce circuit so that when the jack detect feature is enabled it does not toggle multiple times due to input glitches. Slow clock mode must be enabled when using jack insert detect by setting SCLKEN[0] address (0x07).

GPIOPL	CSb/GPIO	NSPKEN/ PSPKEN	MOUTEN	Speaker Enabled	MONO output Enabled
0	0	1	X	Yes	No
0	1	X	1	No	Yes
1	0	X	1	No	Yes
1	1	1	X	Yes	No

Table 21: Jack Insert Detect mode



Bit(s)	Addr	Parameter	Programmable Range
GPIOSEL[2:0]	0x08	GPIO select	0 – CSb Input 1 – Jack Detect 2 – Temperature OK 3 – AMUTE Active 4 – PLL Frequency Output 5 – PLL Lock (0- Locked, 1 – Not Locked) 6 – HIGH 7 – LOW
GPIOPL[3]	0x08	GPIO polarity	0 – Non- Inverted 1 – Inverted
GPIOPLL[4:5]	0x08	GPIO PLL divider	0 – Divide by 1 1 – Divide by 2 2 – Divide by 3 3 – Divide by 4
PSPKEN[5]	0x03	Speaker positive terminal enable	0 – Muted 1 – Enabled
NSPKEN[6]	0x03	Speaker negative terminal enable	0 – Muted 1 – Enabled
MOUTEN[7]	0x03	MONO Output enable	0 – Muted 1 – Enabled
SCLKEN[0]	0x07	Slow clock enable	Period $2^{21} * MCLK$

Table 22: Jack Insert Detect controls

### 12.7.3. Thermal Shutdown

The device contains an on-chip temperature sensor that senses the temperature inside the package. By enabling the temperature sensor interrupt in GPIOSEL[2:0] address (0x08), an interrupt will be generated if the temperature reaches a threshold of approximately 125°C. This facilitates control of the temperature should the device get close to the junction temperature. Note that there is no filtering associated with this temperature alarm since the package has an intrinsic thermal time constant. The thermal temperature is enabled by setting TSEN[1] address (0x31).

Bit(s)	Addr	Parameter	Programmable Range
TSEN[1]	0x31	Temperature Sense Enable	0: Thermal Shutdown Disable 1: Thermal Shutdown Enable

Table 23: Thermal Shutdown

12.8. CLOCK GENERATION BLOCK

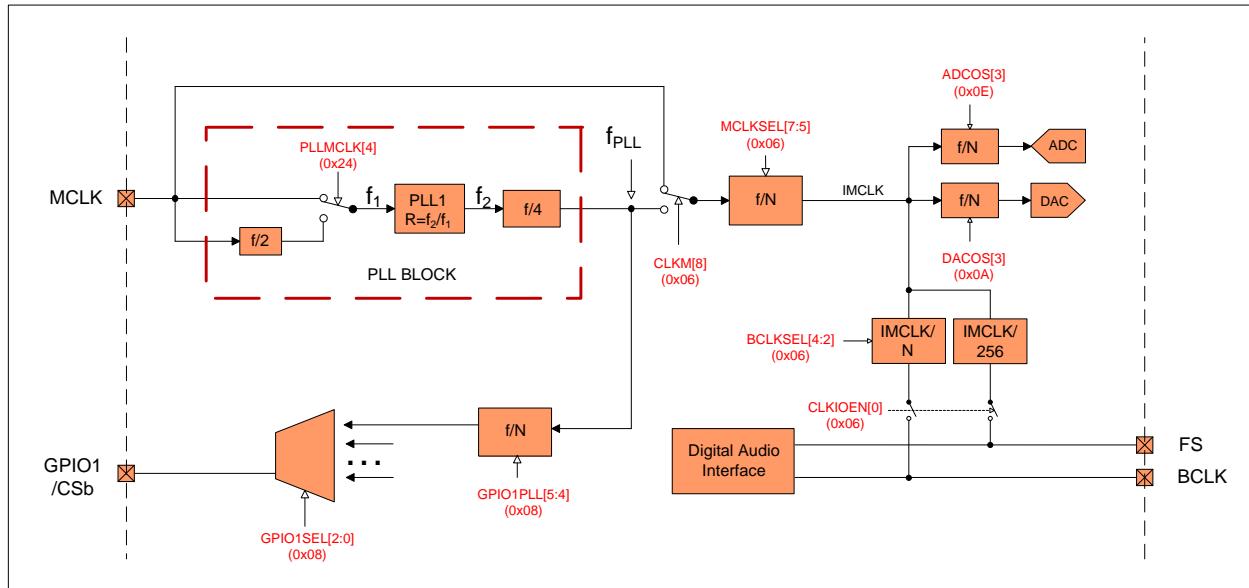

Figure 20: PLL and Clock Select Circuit

The NAU88C14 has two basic clock modes that support the ADC and DAC data converters. It can accept external clocks in the slave mode, or in the master mode, it can generate the required clocks from an external reference frequency using an internal PLL (Phase Locked Loop). The internal PLL is a fractional type scaling PLL, and therefore, a very wide range of external reference frequencies can be used to create accurate audio sample rates.

Separate from this ADC and DAC clock subsystem, audio data are clocked to and from the NAU88C14 by means of the control logic described in the Digital Audio Interfaces section. The Frame Sync (FS) and Bit Clock (BCLK) pins in the Digital Audio Interface manage the audio bit rate and audio sample rate for this data flow.

It is important to understand that the Digital Audio Interface does not determine the sampling rate for the ADC and DAC data converters, and instead, this rate is derived exclusively from the Internal Master Clock (IMCLK). It is therefore a requirement that the Digital Audio Interface and data converters be operated synchronously, and that the FS, BCLK, and IMCLK signals are all derived from a common reference frequency. If these three clocks signals are not synchronous, audio quality will be reduced.

The IMCLK is always exactly 256 times the sampling rate of the data converters. IMCLK is output from the Master Clock Prescaler. The prescaler reduces by an integer division factor the input frequency input clock. The source of this input frequency clock is either the external MCLK pin, or the output from the internal PLL Block.

Addr	D8	D7	D6	D5	D4	D3	D2	D1	D0	Default
0x01	DCBUFEN	0	AUXEN	PLEN	MICBIASEN	ABIASEN	IOBUFEN	REFIMP		
0x06	CLKM	MCLKSEL[2:0]			BCLKSEL[2:0]			0	CLKIOEN	0x140
0x07	0	0	0	0	0	SMPLR[2:0]		SCLKEN	0x000	
0x24	0	0	0	0	PLLMCLK	PLLN[3:0]			0x008	
0x25	0	0	0	PLLK[23:18]						0x00C
0x26	PLLK[17:9]									0x093
0x27	PLLK[8:0]									0x0E9

Table 24: Registers associated with PLL

In Master Mode, the IMCLK signal is used to generate FS and BCLK signals that are driven onto the FS and BCLK pins and input to the Digital Audio Interface. FS is always IMCLK/256 and the duty cycle of FS is automatically adjusted to be correct for the mode selected in the Digital Audio Interface. The frequency of BCLK may optionally be divided to optimize the bit clock rate for the application scenario.

In Slave Mode, there is no connection between IMCLK and the FS and BCLK pins. In this mode, FS and BCLK are strictly input pins, and it is the responsibility of the system designer to insure that FS, BCLK, and IMCLK are synchronous and scaled appropriately for the application.

### 12.8.1. Phase Locked Loop (PLL) General description

The PLL may be optionally used to multiply an external input clock reference frequency by a high resolution fractional number. To enable the use of the widest possible range of external reference clocks, the PLL block includes an optional divide-by-two prescaler for the input clock, a fixed divide-by-four scaler on the PLL output, and an additional programmable integer divider that is the Master Clock Prescaler.

The high resolution fraction for the PLL is the ratio of the desired PLL oscillator frequency ( $f_2$ ), and the reference frequency at the PLL input ( $f_1$ ). This can be represented as  $R = f_2/f_1$ , with R in the form of a decimal number: xy.abcdefgh. To program the NAU88C14, this value is separated into an integer portion (“xy”), and a fractional portion, “abcdefgh”. The fractional portion of the multiplier is a value that when represented as a 24-bit binary number (stored in three 9-bit registers on the NAU88C14), very closely matches the exact desired multiplier factor.

To keep the PLL within its optimal operating range, the integer portion of the decimal number (“xy”), must be any of the following decimal values: 6, 7, 8, 9, 10, 11, or 12. The input and output dividers outside of the PLL are often helpful to scale frequencies as needed to keep the “xy” value within the required range. Also, the optimum PLL oscillator frequency is in the range between 90MHz and 100MHz, and thus, it is best to keep  $f_2$  within this range.

In summary, for any given design, choose:

Equations	Description	Notes
$IMCLK = (256) * (\text{desired codec sample rate})$	$IMCLK = \text{desired Master Clock}$	
$f_2 = (4 * P * IMCLK)$	where P is the Master Clock divider integer value; optimal $f_2$ : $90\text{MHz} < f_2 < 100\text{MHz}$	The integer values for D and P are chosen to keep the PLL in its optimal operating range. It may be best to assign initial values of 1 to both D and P, and then by inspection, determine if they should be a different value.
$F_1 = (MCLK * D)$	where D is the PLL Prescale factor of 1, or 2, and MCLK is the frequency at the MCLK pin	
$R = f_2 / f_1 = xy.\text{abcdefgh}$ decimal value	which is the fractional frequency multiplication factor for the PLL	
$N = xy$	truncated integer portion of the R value and limited to decimal value 6, 7, 8, 9, 10, 11, or 12	
$K = (2^{24}) * (0.\text{abcdefgh})$	rounded to the nearest whole integer value then converted to a binary 24-bit value	

Table 25: Registers associated with PLL

### 12.8.2. CSB/GPIO as PLL out ( $f_{PLL}$ )

CSB/GPIO is a multi-function pin that may be used for a variety of purposes. If not required for some other purpose, this pin may be configured to output the clock frequency from the PLL subsystem. This is the same frequency that is available from the PLL subsystem as the input to the Master Clock Prescaler. This frequency may be optionally divided by an additional integer factor of 2, 3, or 4, before being output on GPIO.

### 12.8.3. Phase Locked Loop (PLL) Design Example

In an example application, a desired sample rate for the DAC is known to be 48.000kHz. Therefore, it is also known that the IMCLK rate will be 256fs, or 12.288MHz. Because there is a fixed divide-by-four scaler on the PLL output, then the desired PLL oscillator output frequency will be 49.152MHz.

In this example system design, there is aly an available 12.000MHz clock from the USB subsystem. To reduce system cost, this clock will also be used for audio. Therefore, to use the 12MHz clock for audio, the desired fractional multiplier ratio would be  $R = 49.152/12.000 = 4.096$ . This value, however, does not meet the requirement that the “xy” whole number portion of the multiplier be in the inclusive range between 6 and 12. To meet the requirement, the Master Clock Prescaler can be set for an additional divide-by-two factor. This now makes the PLL required oscillator frequency 98.304 MHz, and the improved multiplier value is now  $R = 98.304/12.000 = 8.192$ .

To complete this portion of the design example, the integer portion of the multiplier is truncated to the value, 8 and the fractional portion is multiplied by  $2^{24}$ , as to create the needed 24-bit binary fractional value. The calculation for this is:  $(2^{24})(0.192) = 3221225.472$ .

It is best to round this value to the nearest whole value of 3221225, or hexadecimal 0x3126E9.

Below are additional examples of results for this calculation applied to commonly available clock frequencies and desired IMCLK 256fs sample rates.

MCLK (MHz)	Desired Output (MHz)	Input Frequency ( $f_1$ )	$f_2$ (MHz)	MCLK Divider bits	R	N (Hex)	K (Hex)	Actual Register Setting		
								PLLK[23:18]	PLLK[17:9]	PLLK[8:0]
12.0	11.28960	MCLK/1	90.3168	$f_{PLL}/2$	7.526400	7	86C226	21	161	26
12.0	12.28800	MCLK/1	98.3040	$f_{PLL}/2$	8.192000	8	3126E9	0C	93	E9
14.4	11.28960	MCLK/1	90.3168	$f_{PLL}/2$	6.272000	6	45A1CA	11	D0	1CA
14.4	12.28800	MCLK/1	98.3040	$f_{PLL}/2$	6.826667	6	D3A06D	34	1D0	6D
19.2	11.28960	MCLK/2	90.3168	$f_{PLL}/2$	9.408000	9	6872B0	1A	39	B0
19.2	12.28800	MCLK/2	98.3040	$f_{PLL}/2$	10.240000	10	3D70A3	0F	B8	A3
19.8	11.28960	MCLK/2	90.3168	$f_{PLL}/2$	9.122909	9	1F76F8	07	1BB	F8
19.8	12.28800	MCLK/2	98.3040	$f_{PLL}/2$	9.929697	9	EE009E	3B	100	9E
24.0	11.28960	MCLK/2	90.3168	$f_{PLL}/2$	7.526400	7	86C226	21	161	26
24.0	12.28800	MCLK/2	98.3040	$f_{PLL}/2$	8.192000	8	3126E9	0C	93	E9
26.0	11.28960	MCLK/2	90.3168	$f_{PLL}/2$	6.947446	6	F28BD4	3C	145	1D4
26.0	12.28800	MCLK/2	98.3040	$f_{PLL}/2$	7.561846	7	8FD526	23	1EA	126

Table 26: PLL Frequency Examples

## 12.9. CONTROL INTERFACE

The NAU88C14 features two serial bus interfaces SPI and 2-Wire that provide access to the control registers. The MODE pin in conjunction with SPIEN[8] (address 0x49) as shown in the following Table selects the control interfaces. 2-Wire interface is compatible with industry I<sup>2</sup>C serial bus protocol using a bidirectional data signal (SDIO) and a clock signal (SCLK). SPI interface is also compatible with other industry interfaces allowing operation on a simple 3-wire bus. Table below describes the selection of the protocol modes.

MODE Pin	SPIEN[8] Bit (0x49)	Description
0	0	2-Wire Interface (Write/)
1	0	SPI Interface 16-bit (Write)
x	1	SPI Interface 24-bit (Write)

Table 27: Control Interface Selection

### 12.9.1. SPI Serial Control

The Serial Peripheral Interface (SPI) is one of the widely accepted communication interfaces implemented in Nuvoton's Audio CODEC portfolio. SPI is a software protocol allowing operation on a simple 3-wire bus where the data is transferred MSB first. SPI is a software protocol allowing operation on a simple 3-wire or 4-wire bus where the data is transferred MSB first. NAU88C14 has two different SPI architectures

- 16-bit write ONLY (default)
- 24-bit write

The SPI interface consists of a clock (SCLK), chip select (CSb), serial data input (SDIO) to configure all the internal register contents. SCLK is static, allowing the user to stop the clock and then start it again to resume operations where it left off. The 24-bit write operation consists of 8-bits of device address, 7-bits of control register address, and 9-bits of data. To set the SPI 24-bit Write Mode pin is set to "0" and SPIEN[8] address (0x49) is set to "1".

The device address

- Write operation is 00010000b = 10h

#### 12.9.1.1. 16-bit Write Operation (default)

The default control interface architecture is SPI 16-bit. This interface architecture consists of 7-bits of control register address, and 9-bits of control register data. Setting the MODE Pin to "1" (HIGH) selects the SPI 16-bit. In this mode, the user can only do write operation. The write operation requires a valid control register address, then a valid 9-bit Data Byte and the finally to complete the transaction the CSb has to transition from LOW to HIGH to latch the last 9-bits (data).

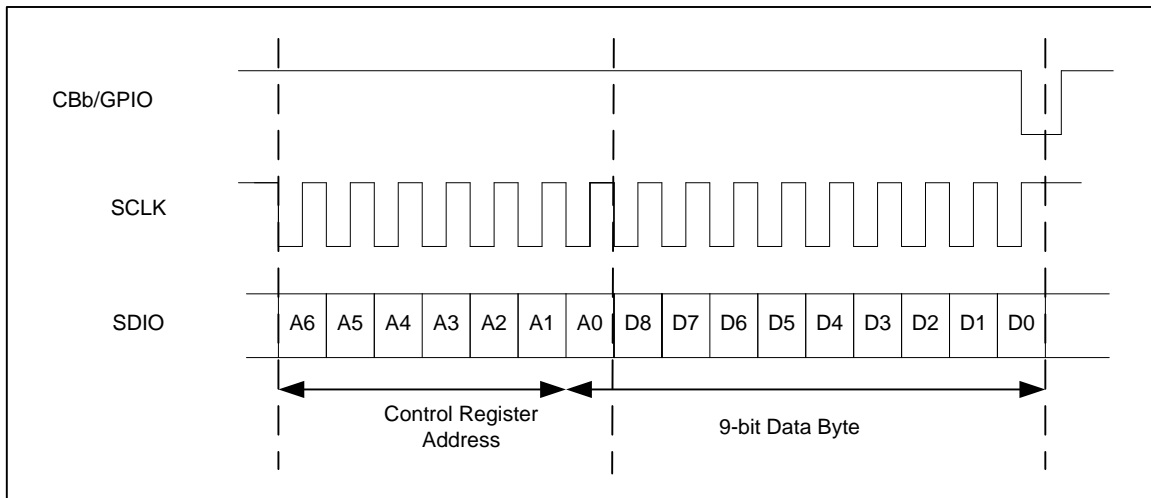

Figure 21: Register write operation using a 16-bit SPI Interface

### 12.9.1.2. 24-bit Write Operation

The 24-bit write operation is a three-byte operation. To start the operation the host controller transitions the CSb from HIGH to LOW. The host micro-controller sends valid device address, then a valid control register address following Data Byte. Finally the interface is terminated by toggling CSb pin from LOW to HIGH. The write operation will accept multiple 9-bit DATA blocks, which will be written in to sequential address beginning with the address, specified in the control register address. Steps below show the procedure to enter and exit SPI 24-bit write

#### Procedure to enter the 24-bit SPI interface

- Set the Mode pin to "0" (LOW)
- Use the 2-wire write architecture to write to register address 0x049 SPIEN[8] = "1" (HIGH)  
OR
- Set the Mode pin to "1" (HIGH)
- Use the 16-bit write architecture to write to register address 0x049 SPIEN[8] = "1" (HIGH)

#### Procedure to exit the 24-bit SPI interface

- Use the 24-bit write architecture to write to register address 0x49 SPIEN[8] = "0" (LOW)
- Depending on the state of the Mode pin, control interface will be selected
  - Mode Pin = "0" for I2C
  - Mode Pin = "1" for 16-bit SPI

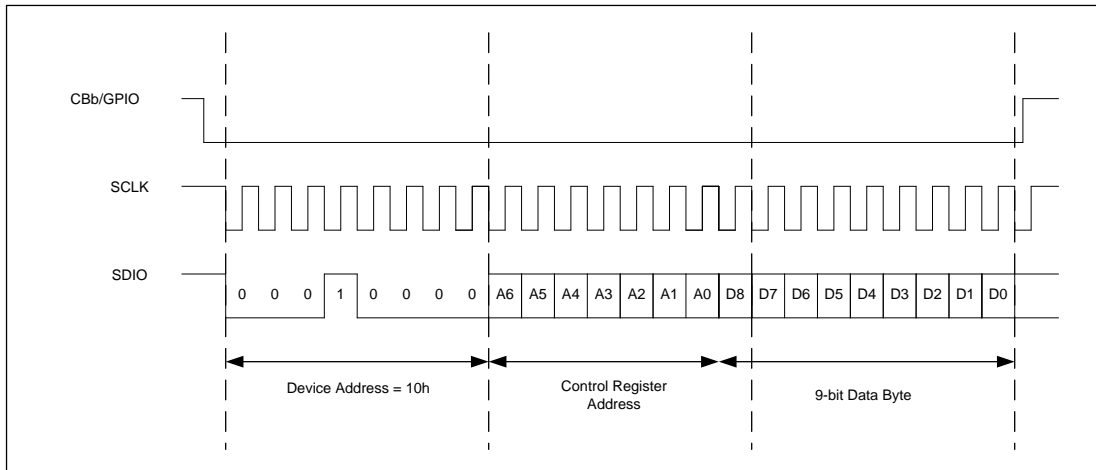

Figure 22: Register Write operation using a 24-bit SPI Interface

### 12.9.2. 2-WIRE Serial Control Mode (I<sup>2</sup>C Style Interface)

The NAU88C14 supports a bidirectional bus oriented protocol. The protocol defines any device that sends data onto the bus as a transmitter and the receiving device as the receiver. Therefore, the 2-Wire operates as slave interface. All communication over the 2-Wire interface is conducted by sending the MSB of each byte of data first.

#### 12.9.2.1. 2-WIRE Protocol Convention

All 2-Wire interface operations must begin with a START condition, which is a HIGH to LOW transition of SDIO while SCLK is HIGH. All 2-Wire and all interface operations are terminated by a STOP condition, which is a LOW to HIGH transition of SDIO while SCLK is HIGH. A STOP condition at the end of a read or write operation places the device in standby mode. An acknowledge (ACK), is a software convention used to indicate a successful data transfer. The transmitting device, either master or slave, releases the SDIO bus after transmitting eight bits. During the ninth clock cycle, the receiver pulls the SDIO line LOW to acknowledge the reception of the eight bits of data.

Following a START condition, the master must output a device address byte. The 7-MSB bits “0011010” are the device address. The LSB of the device address byte is the R/W bit and defines a read (R/W = 0) or write (R/W = 1) operation. When this, R/W, bit is a “1”, then a read operation is selected and when “0” the device selects a write operation. The device outputs an acknowledge LOW for a correct device address and HIGH for an incorrect device address on the SDIO pin.



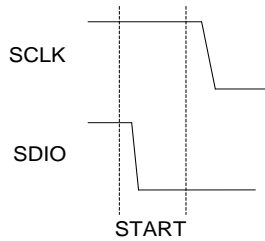

Figure 23: Valid START Condition

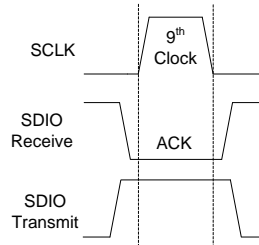

Figure 24: Valid Acknowledge

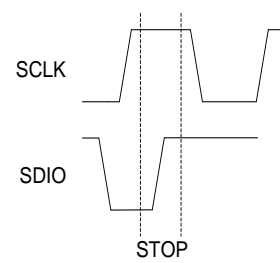

Figure 25: Valid STOP Condition

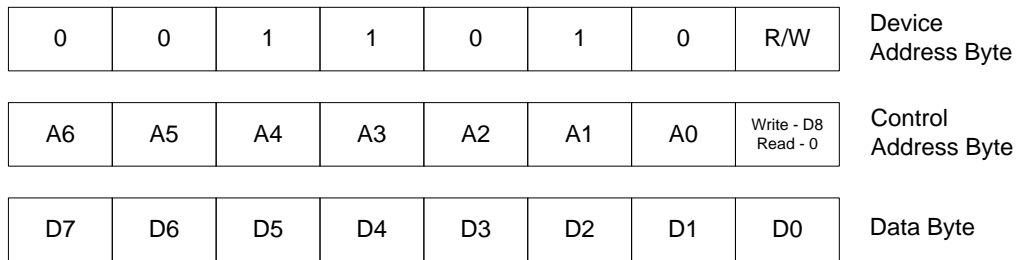

Figure 26: Slave Address Byte, Control Address Byte, and Data Byte

### 12.9.2.2. 2-WIRE Write Operation

A Write operation consists of a two-byte instruction followed by one or more Data Bytes. A Write operation requires a START condition, followed by a valid device address byte, a valid control address byte, data byte(s), and a STOP condition. After each three bytes sequence, the NAU88C14 responds with an ACK and the 2-Wire interface enters a standby state.

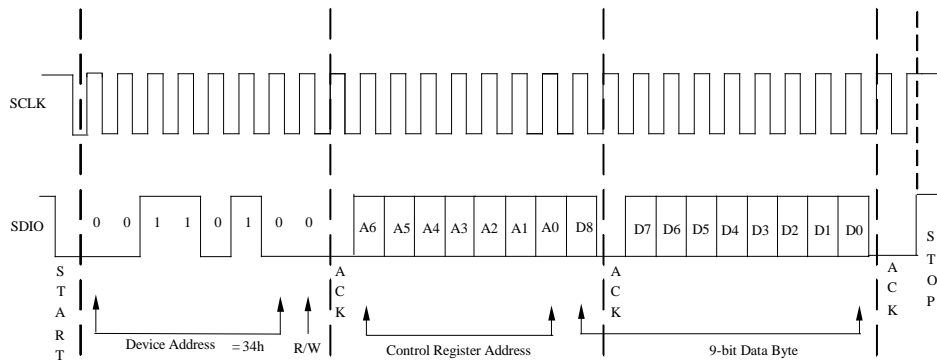

Figure 27: Byte Write Sequence

**12.9.2.3. 2-WIRE Operation**

A operation consists of a three-byte instruction followed by one or more Data Bytes. The master initiates the operation issuing the following sequence: a START condition, device address byte with the R/W bit set to “0”, a control address byte, a second START condition, and a second device address byte with the R/W bit set to “1”.

After each of the three bytes, the NAU88C14 responds with an ACK. Then the NAU88C14 transmits Data Bytes as long as the master responds with an ACK during the SCLK cycle following the ninth bit of each byte. The master terminates the operation (issuing a STOP condition) following the last bit of the last Data Byte.

After reaching the memory location 7Fh the pointer “rolls over” to 00h, and the device continues to output data for each ACK received.

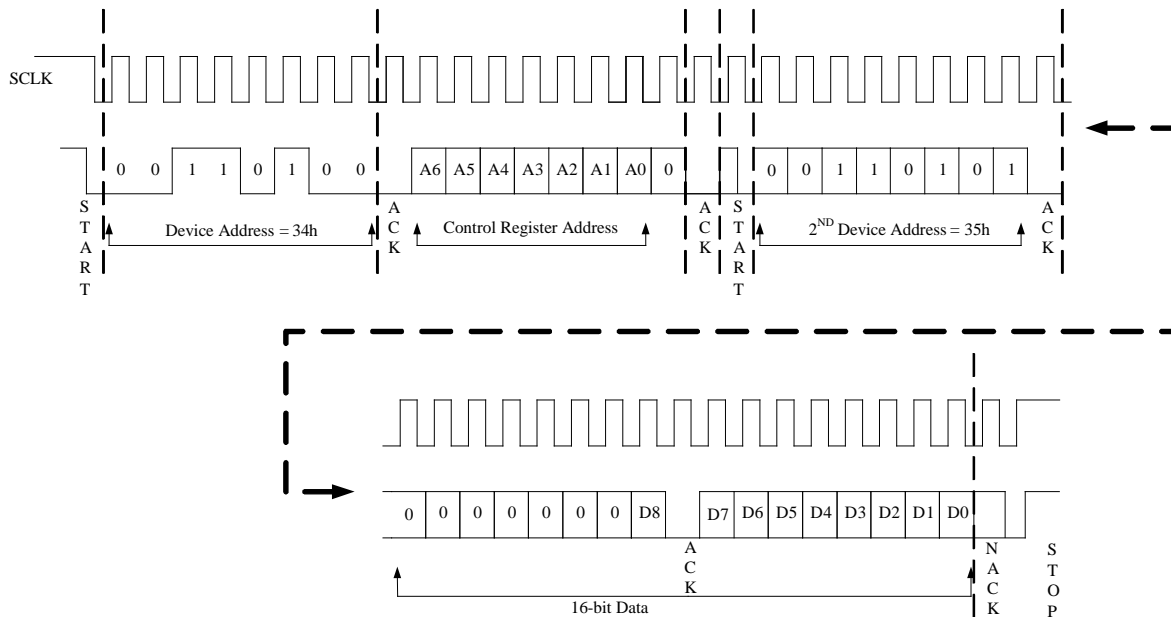

Figure 28: 2-Wire Read Sequence

## 12.10. DIGITAL AUDIO INTERFACES

NAU88C14 only uses the Left channel to transfer data in normal mode. It supports an independent digital interface for voice and audio. The digital interface is used to input digital data to the DAC, or output digital data from the ADC. The digital interface can be configured to Master mode or Slave mode.

Master mode is configured by setting CLKIOEN[0] address (0x06) bit to HIGH. The main clock (MCLK) of the digital interface is provided from an external clock either from a crystal oscillator or from a microcontroller. With an appropriate MCLK, the device generates bit clock (BCLK) and frame sync (FS) internally in the master mode. By generating the bit clock and frame sync internally, the NAU88C14 has full control of the data transfer.

Slave mode is configured by setting CLKIOEN[0] address (0x06) bit to LOW. In this mode, an external controller has to supply the bit clock and the frame sync. The NAU88C14 uses ADCOUT, DACIN, FS, and BCLK pins to control the digital interface. Care needs to be exercised when designing a system to operate the NAU88C14 in this mode as the relationship between the sample rate, bit clock, and frame sync needs to be controlled by other controller. In both modes of operation, the internal MCLK and MCLK prescalers determine the sample rate for the DAC and ADC.

The output state of the ADCOUT pin by default is pulled-low. Depending on the application, the output can be configured to be Hi-Z, pull-low, pull-high, Low or High. To configure the output, three different bits have to be set. First the output switched to the mask by setting PUDOEN[5] address (0x3C), then the mask has to be enabled by setting PUDPE[4] address (0x3C) and finally output state select pulled up or down by PUDPS[3] address (0x3C). Six different audio formats are supported by NAU88C14 with MSB first and they are as follows.

AIFMT[4] Addr: (0x04)	AIFMT[3] Addr: (0x04)	PCMTSEN[8] Addr: (0x3C)	PCMB[1] Addr: (0x3C)	PCM Mode
0	0	0	1	PCM B
0	0	0	0	Right Justified
0	1	0	0	Left Justified
1	0	0	0	I <sup>2</sup> S
1	1	0	0	PCM A
1	1	1	0	PCM Time Slot

Table 28: Standard Interface modes

Addr	D8	D7	D6	D5	D4	D3	D2	D1	D0	Default
0x04	BCLKP	FSP	WLEN[1:0]		AIFMT[1:0]		DACPHS	ADCPHS	0	0x050
0x06	CLKM	MCLKSEL[2:0]			BCLKSEL[2:0]			0	CLKIOEN	0x140
0x3B	TSLOT[8:0]									0x000
0x3C	PCMTSEN	TRI	PCM8BIT	PUDOEN	PUDPE	PUDPS	LOUTR	PCMB	TSLOT[9:8]	0x000

Table 29: Audio Interface Control Registers

**12.10.1. Right Justified audio data**

In right justified interface (normal mode), the left channel serial audio data is synchronized with the frame sync. Left channel data is transferred during the HIGH frame sync. The MSB data is sampled first. The data is latched on the last rising edge of BCLK before frame sync transition (FS). The LSB is aligned with the falling edge of the frame sync signal (FS). Right justified format is selected by setting AIFMT[1:0] address (0x04) to “00” binary in conjunction with PCMTSEN[8] address (0x3C) set to LOW.

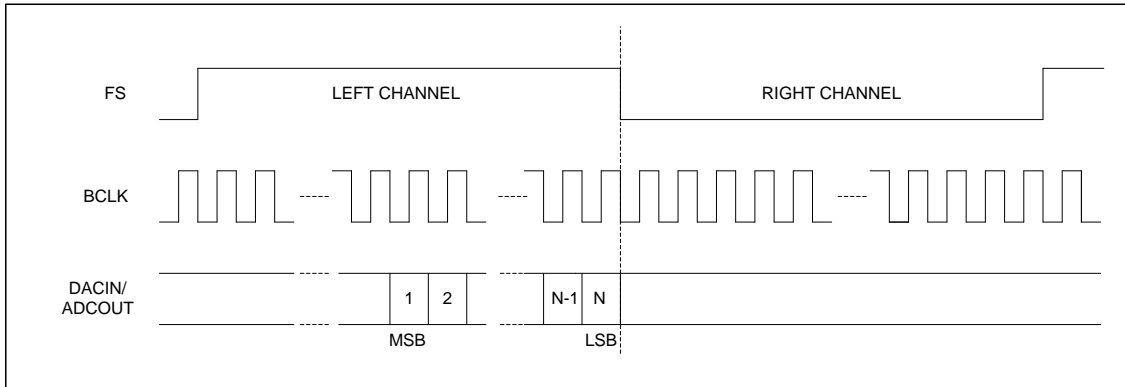

Figure 29: Right Justified Audio Interface (Normal Mode)

NAU88C14 features a special mode where the device outputs Left channel data to both Left and Right channels. This is accomplished by setting LOUTr[2] address (0x3C) to “1”

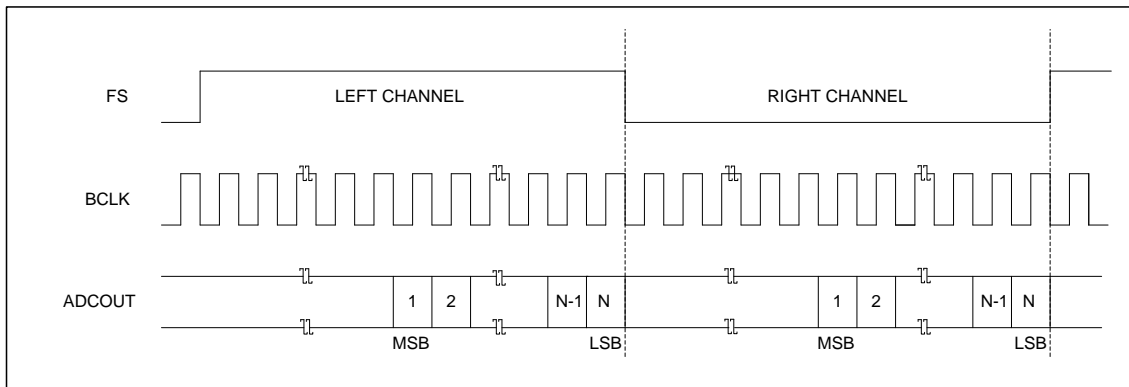
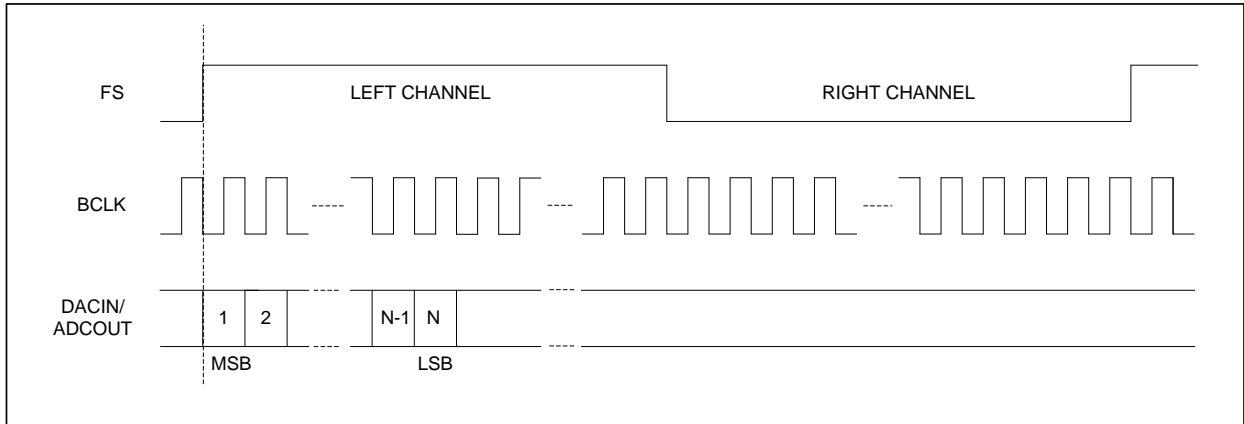

Figure 30: Right Justified Audio Interface (Special mode)

**12.10.2. Left Justified audio data**

In Left justified interface (normal mode), the left channel serial audio data is synchronized with the frame sync. Left channel data is transferred during the HIGH frame sync. The MSB data is sampled first and is available on the first rising edge of BCLK following a frame sync transition (FS). Left justified format is selected by setting AIFMT[1:0] address (0x04) to "01" binary in conjunction with PCMTSEN[8] address (0x3C) set to LOW.



**Figure 31: Left Justified Audio Interface (Normal Mode)**

NAU88C14 features a special mode where the device outputs Left channel data to both Left and Right channels. This is accomplished by setting LOUTr[2] address (0x3C) to "1"

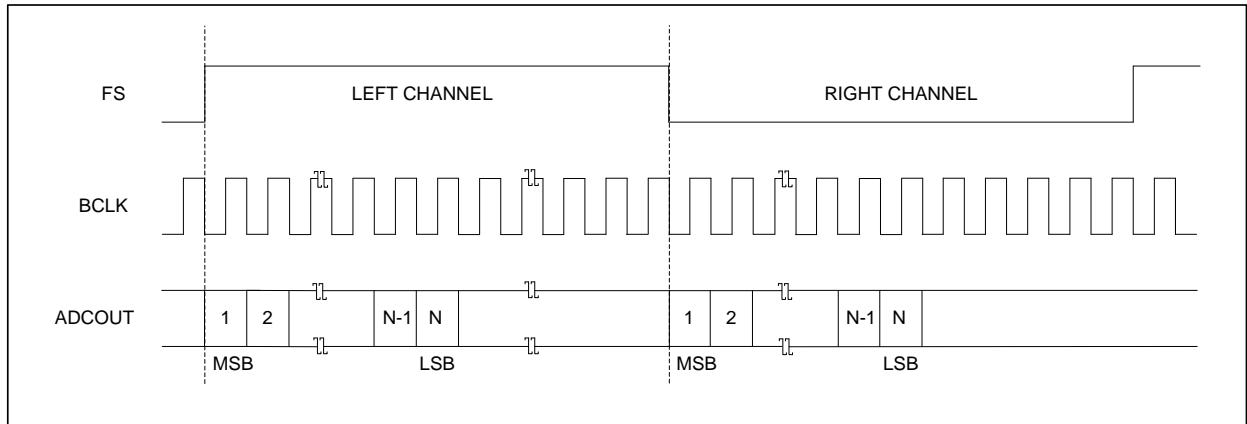

**Figure 32: Left Justified Audio Interface (Special mode)**

**12.10.3. I<sup>2</sup>S audio data**

In I<sup>2</sup>S interface (normal mode), the left channel serial audio data is synchronized with the frame sync. Left channel data is transferred during the LOW frame sync. The MSB data is sampled first. The data is latched on the second rising edge of BCLK following a frame sync transition (FS). I<sup>2</sup>S format is selected by setting AIFMT[1:0] address (0x04) to "10" binary in conjunction with PCMTSEN[8] address (0x3C) set to LOW.

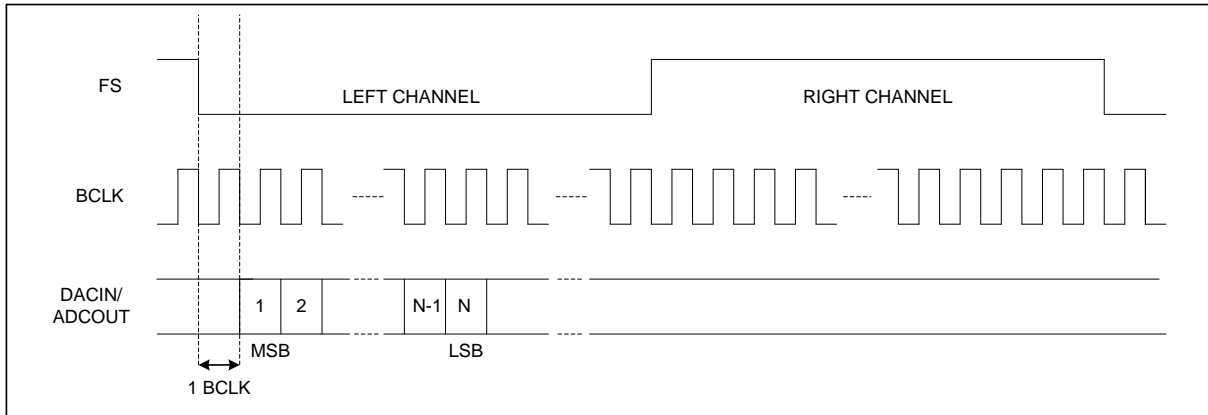

**Figure 33: I2S Audio Interface (Normal Mode)**

NAU88C14 features a special mode where the device outputs Left channel data to both Left and Right channels. This is accomplished by setting LOU<sub>TR</sub>[2] address (0x3C) to "1"

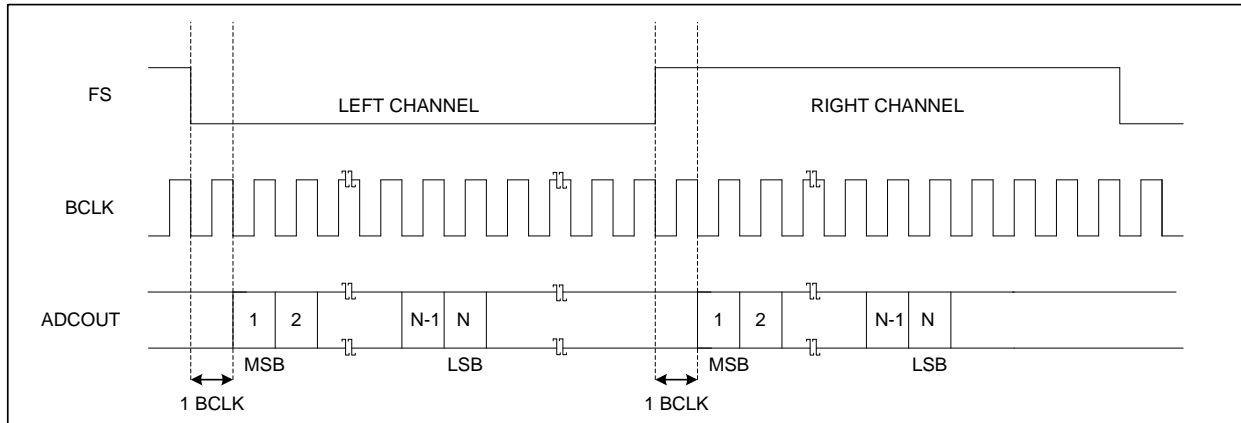
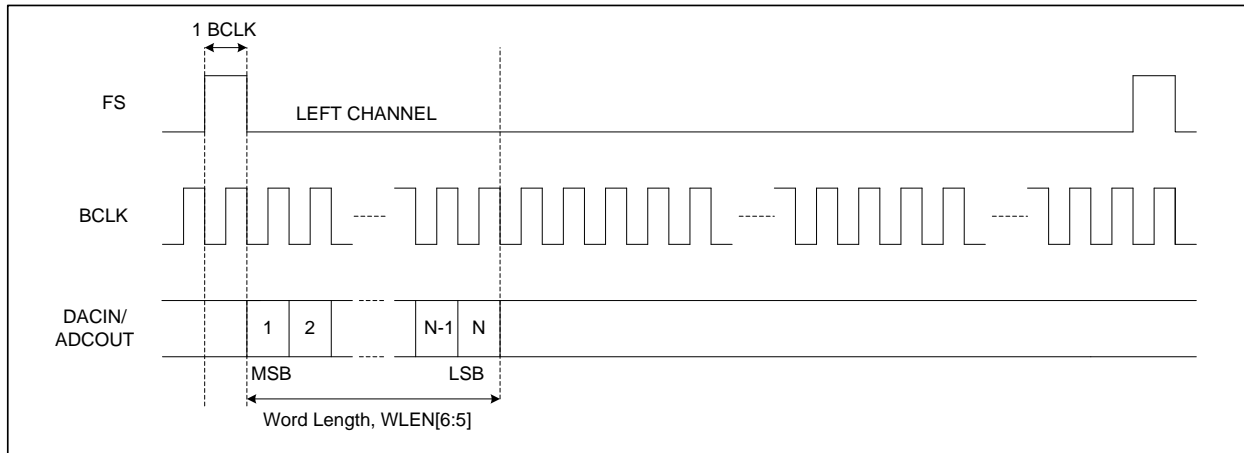

**Figure 34: I2S Audio Interface (Special mode)**

**12.10.4. PCM audio data**

In PCM interface (normal mode), the left channel serial audio data is synchronized with the frame sync. Left channel data is transferred during the LOW frame sync. The MSB data is sampled first. The data is latched on the second rising edge of BCLK following a frame sync transition (FS). PCM format is selected by setting AIFMT[4:3] address (0x04) to “11” binary in conjunction with PCMTSEN[8] address (0x3C) set to LOW.

The digital data can be forced to appear on the right phase of the FS by setting ADCPHS[0] and DACPHS[1] address (0x04) bits to HIGH respectively. The starting point of the right phase data depends on the word length WLEN[6:5] address (0x04) after the frame sync transition (FS).



**Figure 35: PCM Mode Audio Interface (Normal Mode)**

NAU88C14 features a special mode where the device outputs Left channel data to both Left and Right channels. This is accomplished by setting LOUTr[2] address (0x3C) to “1”

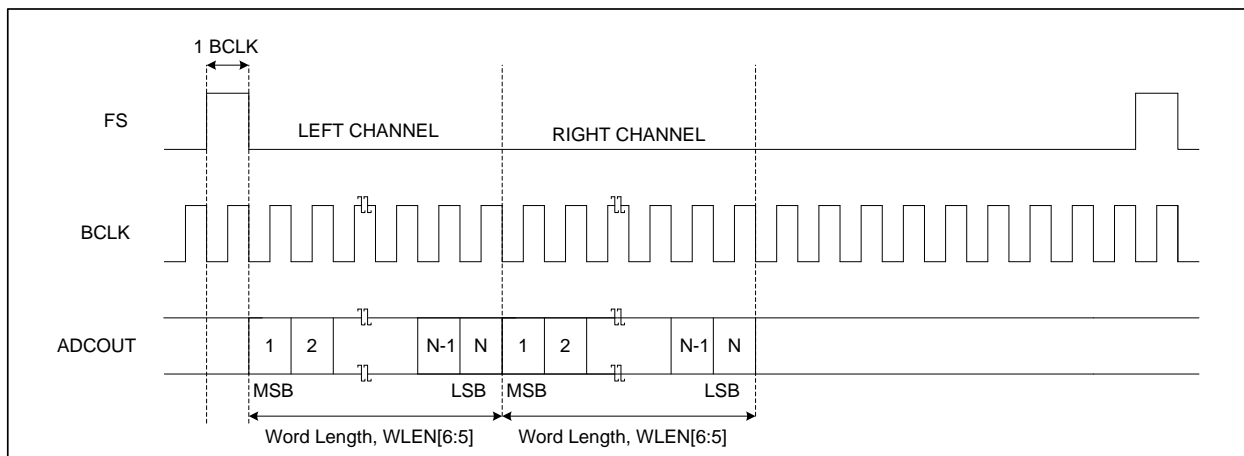

**Figure 36: PCM Mode Audio Interface (Special mode)**

## 12.10.5. PCM Time Slot audio data

In PCM Time-Slot interface (normal mode), the left channel serial audio data is synchronized with the frame sync. Left channel data is transferred during the LOW frame sync. The MSB data is sampled first. The starting point of the timeslot is controlled by a 10-bit byte TSLOT[9:0] address (0x3B and 0x3C). The data is latched on the first rising edge of BCLK following a frame sync transition (FS) providing PCM in timeslot zero (TSLOT[9:0] = 000). PCM Time-Slot format is selected by setting AIFMT[4:3] address (0x04) to “11” binary in conjunction with PCMTSEN[8] address (0x3C) set to HIGH. The digital data can be forced to appear on the right phase of the FS by setting ADCPHS[0] and DACPHS[1] address (0x04) bits to HIGH respectively. The starting point of the right phase data depends on the word length WLEN[6:5] address (0x04) and timeslot assignment TSLOT[9:0] address (0x3B and 0x3C) after the frame sync transition (FS). DACIN will return to the bus condition either on the negative edge of BCLK during the LSB, or on the positive edge of BCLK following the LSB depending on the setting of TRI[7] address (0x3C). Tri-stating on the negative edge allows the transmission of data by multiple sources in adjacent timeslots without the risk of driver contention.

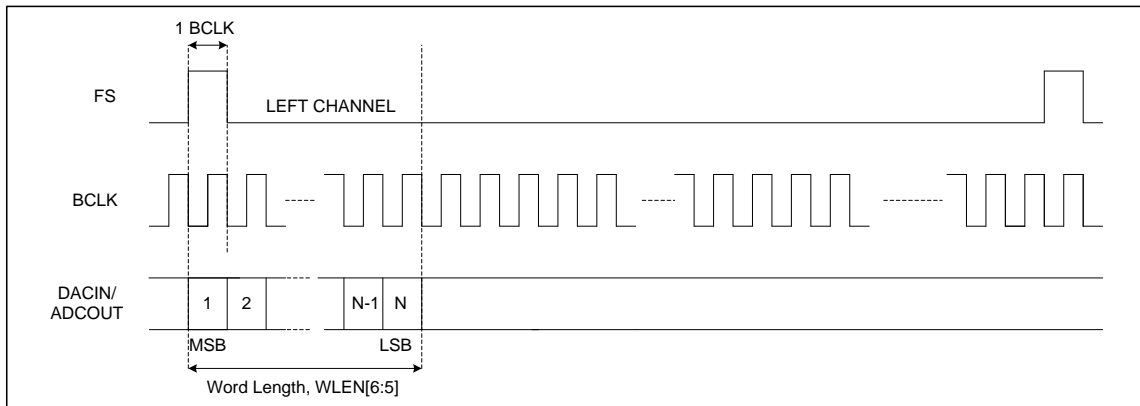

Figure 37: PCM Time Slot Mode (Time slot = 0) (Normal Mode)

NAU88C14 features a special mode where the device outputs Left channel data to both Left and Right channels. This is accomplished by setting LOUTR[2] address (0x3C) to “1”

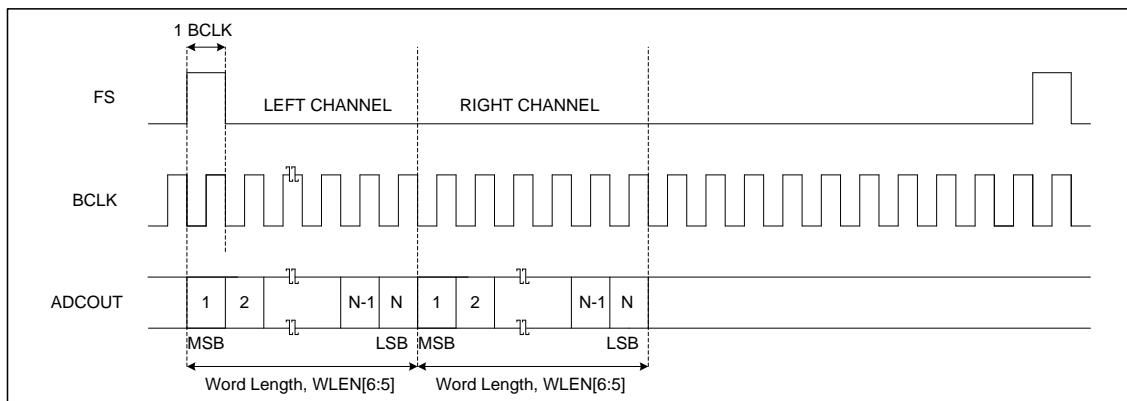

Figure 38: PCM Time Slot Mode (Time slot = 0) (Special mode)



## 12.10.6. Companding

Companding is used in digital communication systems to optimize signal-to-noise ratios with reduced data bit rates, and make use of non-linear algorithms. NAU88C14 supports two different types of companding A-law and  $\mu$ -law on both transmit and receive sides. A-law algorithm is used in European communication systems and  $\mu$ -law algorithm is used by North America, Japan, and Australia. This feature is enabled by setting DACCM[4:3] address (0x05) or ADCCM[2:1] address (0x05) register bits. Companding converts 13 bits ( $\mu$ -law) or 12 bits (A-law) to 8 bits using non-linear quantization. The companded signal is an 8-bit word containing sign (1-bit), exponent (3-bits) and mantissa (4-bits). As recommended by the G.711 standard (all 8-bits are inverted for  $\mu$ -law, all even data bits are inverted for A-law).

Setting CMB8[5] address 0x05 to 1 will cause the PCM interface to use 8-bit word length for data transfer, overriding the word length configuration setting in WLEN[6:5] address 0x04.

Addr	D8	D7	D6	D5	D4	D3	D2	D1	D0	Default
0x05	0	0	0	CMB8	DACCM[1:0]		ADCCM[1:0]		ADDAP	0x000

Table 30: Companding Control

The following equations for data compression (as set out by ITU-T G.711 standard):

**$\mu$ -law (where  $\mu=255$  for the U.S. and Japan):**

$$F(x) = \ln(1 + \mu|x|) / \ln(1 + \mu) \quad -1 \leq x \leq 1$$

**A-law (where A=87.6 for Europe):**

$$F(x) = A|x| / (1 + \ln A) \quad \text{for } x \leq 1/A$$

$$F(x) = (1 + \ln A|x|) / (1 + \ln A) \quad \text{for } 1/A \leq x \leq 1$$

## **12.11. POWER SUPPLY**

This device has been designed to operate reliably using a wide range of power supply conditions and power-on/power-off sequences. There are no special requirements for the sequence or rate at which the various power supply pins change. Any supply can rise or fall at any time without harm to the device. However, pops and clicks may result from some sequences. Optimum handling of hardware and software power-on and power-off sequencing is described in more detail in the Power Up/Down Sequencing section of this document.

### **12.11.1. Power-On Reset**

The NAU88C14 does not have an external reset pin. The device reset function is automatically generated internally when power supplies are too low for reliable operation. The internal reset is generated any time that either VDDA or VDDC is lower than is required for reliable maintenance of internal logic conditions. The threshold voltage for VDDA is approximately ~1.52Vdc and the threshold voltage for VDDC is approximately ~0.67Vdc. Note that these are much lower voltages than are required for normal operation of the chip. These values are mentioned here as general guidance as to overall system design.

If either VDDA or VDDC is below its respective threshold voltage, an internal reset condition may be asserted. During this time, all registers and controls are set to the hardware determined initial conditions. Software access during this time will be ignored, and any expected actions from software activity will be invalid.

When both VDDA and VDDC reach a value above their respective thresholds, an internal reset pulse is generated which extends the reset condition for an additional time. The duration of this extended reset time is approximately 50 microseconds, but not longer than 100 microseconds. The reset condition remains asserted during this time. If either VDDA or VDDC at any time becomes lower than its respective threshold voltage, a new reset condition will result. The reset condition will continue until both VDDA and VDDC again higher than their respective thresholds. After VDDA and VDDC are again both greater than their respective threshold voltage, a new reset pulse will be generated, which again will extend the reset condition for not longer than an additional 100 microseconds.

### **12.11.2. Power Related Software Considerations**

There is no direct way for software to determine that the device is actively held in a reset condition. If there is a possibility that software could be accessing the device sooner than 100 microseconds after the VDDA and VDDC supplies are valid, the reset condition can be determined indirectly. This is accomplished by writing a value to any register other than register 0x00, with that value being different than the power-on reset initial values. The optimum choice of register for this purpose may be dependent on the system design, and it is recommended the system engineer choose the register and register test bit for this purpose. After writing the value, software will then back the same register. When the register test bit s back as the new value, instead of the power-on reset initial value, software can reliably determine that the reset condition has ended.

Although it is not required, it is strongly recommended that a Software Reset command should be issued after power-on and after the power-on-reset condition is ended. This will help insure reliable operation under every power sequencing condition that could occur.

### 12.11.3. Software Reset

The control registers can be reset to default conditions by writing any value to RST address (0x00), using any of the control interface modes. Writing valid data to any other register disables the reset, but all registers will need to be initiated again appropriate to the operation. See the applications section on powering NAU88C14 up for information on avoiding pops and clicks after a software reset.

### 12.11.4. Power Up/Down Sequencing

Most audio products have issues during power up and power down in the form of pop and click noise. To avoid such issues the NAU88C14 provides four different power supplies VDDA, VDDDB, VDDC and VDDSPK with separated grounds VSSA, VSSD and VSSSPK. The audio CODEC circuitry, the input amplifiers, output amplifiers and drivers, the audio ADC and DAC converters, the PLL, and so on, can be powered up and down individually by software control via 2-Wire or SPI interface. The zero cross function should be used when changing the volume in the PGAs to avoid any audible pops or clicks. There are two different modes of operation 5.0V and 3.3V mode. The recommended power-up and power-down sequences for both the modes are outlined as following.

Name	Power Up	
	VDDSPK – 3.3V operation	VDDSPK – 5.0V operation
Power supplies	Analog – VDDA	Analog – VDDA
	Buffer – VDDDB	Buffer – VDDDB
	Digital – VDDC	Digital – VDDC
	Output driver – VDDSPK	Output driver – VDDSPK
Mode	SPKBST[2] = 0	SPKBST[2] = 1
	MOUTBST[3] = 0	MOUTBST[3] = 1
Power Management	REFIMP[1:0] as required (value of the REFIMP bits based on the startup time which is a combination of the reference impedance and the decoupling capacitor on VREF)	
	ABIASEN[3] = 1 (enables the internal device bias for all analog blocks)	
	IOBUFEN[2] = 1 (enables the internal device bias buffer)	
Clock divider	CLKIOEN[0] if required	CLKIOEN[0] if required
	BCLKSEL[4:2] if required	BCLKSEL[4:2] if required
	MCLKSEL[7:5] if required	MCLKSEL[7:5] if required
PLL	PLLEN[5] if required	PLLEN[5] if required
DAC, ADC	DACEN[0] = 1	DACEN[0] = 1
	ADCEN[0] = 1	ADCEN[0] = 1
Mixers	SPKMXEN[2]	SPKMXEN[2]

Power Up		
Name	VDDSPK – 3.3V operation	VDDSPK – 5.0V operation
	MOUTMXEN[3]	MOUTMXEN[3]
Output stages	MOUTEN[7]	MOUTEN[7]
	NSPKEN[6]	NSPKEN[6]
	PSPKEN[5]	PSPKEN[5]
Un-mute DAC	DACMT[6] = 0	DACMT[6] = 0

Table 31: Power up sequence

Name	Power Down Both Cases
Un-mute DAC	DACMT[6] = 1
Power Management	PWRM1 = 0x000
Output stages	MOUTEN[7]
	NSPKEN[6]
	PSPKEN[5]
Power supplies	Analog – VDDA
	Buffer – VDDB
	Digital – VDDC
	Output driver – VDDSPK

Table 32: Power down Sequence

#### 12.11.5. Reference Impedance (REFIMP) and Analog Bias

Before the device is functional or any of the individual analog blocks are enabled REFIMP[1:0] address (0x01) and ABIASEN[3] address (0x01) must be set. The REFIMP[1:0] bits control the resistor values (“R” in Figure3) that generates the mid supply reference, VREF. REFIMP[1:0] bits control the power up ramp rate in conjunction with the external decoupling capacitor. A small value of “R” allows fast ramp up of the mid supply reference and a large value of “R” provides higher PSRR of the mid supply reference.

The master analog biasing of the device is enabled by setting ABIASEN[3] address (0x01). This bit has to be set before for the device to function.

#### 12.11.6. Power Saving

Saving power is one of the critical features in a semiconductor device specially ones used in the Bluetooth headsets and handheld device. NAU88C14 has two oversampling rates 64x and 128x. The default mode of operation for the DAC and ADC is in 64x oversampling mode which is set by programming DACOS[3] address (0x0A) and ADCOS[3] address (0x0E) respectively to LOW. Power is saved by choosing 64x oversampling rate compared to 128x

oversampling rate but slightly degrades the noise performance. To each lowest power possible after the device is functioning set ABIASEN[3] address (0x01) bit to LOW.

Addr	D8	D7	D6	D5	D4	D3	D2	D1	D0	Default
<b>0x01</b>	DCBUFEN	0	AUXEN	PLLEN	MICBIASEN	ABIASEN	IOBUFEN	REFIMP		<b>0x000</b>
<b>0x0A</b>	0	0	DACMT	DEEMP[1:0]		DACOS	AUTOMT	0	DACPL	<b>0x000</b>
<b>0x0E</b>	MOUTFEN	MOUTFAM	MOUTF[2:0]			ADCOS	0	0	ADCPL	<b>0x100</b>
<b>0x3A</b>	LPIPBST	LPADC	LPSPKD	LPDAC	MICBIASM	TRIMREG[3:2]		IBADJ[1:0]		<b>0x000</b>

Table 33: Registers associated with Power Saving

### 12.11.7. Estimated Supply Currents

NAU88C14 can be programmed to enable or disable various analog blocks individually. The table below shows the amount of current consumed by certain analog blocks. Sample rate settings will vary current consumption of the VDDC supply. VDDC consumes approximately 4mA with VDDC = 1.8V and fs = 48kHz. Lower sampling rates will draw lower current.

BIT	Address	VDDA CURRENT
REFIMP[1:0]	0x01	10K => 300 uA 161k/595k < 100 uA
IOBUFEN[2]		40uA
ABIASEN[3]		600uA
MICBIASEN[4]		500 uA
PLLEN[5]		2.5mA Clocks Applied
DCBUFEN[8]		80uA
ADCEN[0]	0x02	x64 - ADCOS= 0 => 2.0mA x128 - ADCOS= 1 => 3.0mA
PGAEN[2]		400uA
BSTEN[4]		200 uA
DACEN[0]	0x03	X64 (DACOS=0)=>1.6mA x128(DACOS=1)=>1.7mA
SPKMXEN[2]		400uA
MOUTMXEN[3]		200uA
NSPKEN[6]		1mA from VDDSPK + 100uA (VDDA = 5V mode)
PSPKEN[5]		1mA from VDDSPK + 100uA (VDDA = 5V mode)
MOUTEN[7]		100uA

Table 34: VDDA 3.3V Supply Current

### 13. REGISTER DESCRIPTION

Register Address		Register Names	Register Bits									Default
DEC	HEX		D8	D7	D6	D5	D4	D3	D2	D1	D0	
0	0	Software Reset	RESET (SOFTWARE)									000
<b>POWER MANAGEMENT</b>												
1	01	Power Management 1	DCBUFEN	0	AUXEN	PLEN	MICBIASEN	ABIASEN	IOBUFEN	REFIMP		000
2	02	Power Management 2	0	0	0	0	BSTEN	0	PGAEN	0	ADCEN	000
3	03	Power Management 3	0	MOUTEN	NSPKEN	PSPKEN	0	MOUTMXEN	SPKMXEN	0	DACEN	000
<b>AUDIO CONTROL</b>												
4	04	Audio Interface	BCLKP	FSP	WLEN[1:0]		AIFMT[1:0]		DACPHS	ADCPHS	0	050
5	05	Companding	0	0	0	0	DACCM[1:0]		ADCCM[1:0]		ADDAP	000
6	06	Clock Control 1	CLKM	MCLKSEL[2:0]			BCLKSEL[2:0]			0	CLKIOEN	140
7	07	Clock Control 2	0	0	0	0	0	SMPLR[2:0]			SCLKEN	000
8	08	GPIO CTRL	0	0	0	GPIOPLL[1:0]		GPIOPL	GPIOSEL[2:0]			000
10	0A	DAC CTRL	0	0	DACMT	DEEMP[1:0]		DACOS	AUTOMT	0	DACPL	000
11	0B	DAC Volume	0	DACGAIN								OFF
14	0E	ADC CTRL	HPFEN	HPFAM	HPF[2:0]			ADCOS	0	0	ADCPL	100
15	0F	ADC Volume	0	ADCGAIN								OFF
<b>EQUALISER</b>												
18	0x12	EQ1-Low Cutoff	EQM	0	EQ1CF[1:0]		EQ1GC[4:0]				12C	
19	0x13	EQ2-Peak 1	EQ2BW	0	EQ2CF[1:0]		EQ2GC[4:0]				02C	
20	0x14	EQ3-Peak 2	EQ3BW	0	EQ3CF[1:0]		EQ3GC[4:0]				02C	
21	0x15	EQ4-Peak3	EQ4BW	0	EQ4CF[1:0]		EQ4GC[4:0]				02C	
22	0x16	EQ5-High Cutoff	0	0	EQ5CF[1:0]		EQ5GC[4:0]				02C	
<b>DIGITAL TO ANALOG (DAC) LIMITER</b>												
24	18	DAC Limiter 1	DACLIMEN	DACLIMDCY[3:0]				DACLIMATK[3:0]				032
25	19	DAC Limiter 2	0	0	DACLIMTHL[2:0]			DACLIMBST[3:0]				000
<b>NOTCH FILTER</b>												
27	1B	Notch Filter High	NFCU	NFCEN	NFCA0[13:7]							000
28	1C	Notch Filter Low	NFCU	0	NFCA0[6:0]							000
29	1D	Notch Filter High	NFCU	0	NFCA1[13:7]							000
30	1E	Notch Filter Low	NFCU	0	NFCA1[6:0]							000
<b>ALC CONTROL</b>												
32	20	ALC CTRL 1	ALCEN	0	0	ALCMXGAIN[2:0]			ALCMNGAIN[2:0]			038
33	21	ALC CTRL 2	ALCZC	ALCHT[3:0]				ALCSL[3:0]				00B
34	22	ALC CTRL 3	ALCM	ALCDCY[3:0]				ALCATK[3:0]				032
35	23	Noise Gate	0	0	0	0	0	ALCNEN	ALCNTH[2:0]			000
<b>PLL CONTROL</b>												
36	24	PLL N CTRL	0	0	0	0	PLLMCLK	PLLN[3:0]				008
37	25	PLL K 1	0	0	0	PLLK[23:18]					00C	

Register Address		Register Names	Register Bits									Default
DEC	HEX		D8	D7	D6	D5	D4	D3	D2	D1	D0	
38	26	PLL K 2	PLLK[17:9]									093
39	27	PLL K 3	PLLK[8:0]									0E9
<b>INPUT, OUTPUT &amp; MIXER CONTROL</b>												
40	28	Attenuation CTRL	0	0	0	0	0	0	MOUTATT	SPKATT	0	000
44	2C	Input CTRL	MICBIASV		0	0	0	AUXM	AUXPGA	NMICPGA	PMICPGA	003
45	2D	PGA Gain	0	PGAZC	PGAMT	PGAGAIN[5:0]					010	
47	2F	ADC Boost	PGABST	0	PMICBSTGAIN		0	AUXBSTGAIN				100
49	31	Output CTRL	0	0	0	0	0	MOUTBST	SPKBST	TSEN	AOUTIMP	002
50	32	Mixer CTRL	0	0	0	AUXSPK	0	0	0	BYSPK	DACSPK	001
54	36	SPKOUT Volume	0	SPKZC	SPKMT	SPKGAIN[5:0]					039	
56	38	MONO Mixer Control	0	0	MOUTMT	0	0	0	AUXMOUT	BYPMOUT	DACMOUT	001
<b>LOW POWER CONTROL</b>												
58	3A	Power Management 4	LPIPBST	LPADC	LSPSKD	LPDAC	MICBIASM	TRIMREG		IBADJ		000
<b>PCM TIME SLOT &amp; ADCOUT IMPEDANCE OPTION CONTROL</b>												
59	3B	Time Slot	TSLOT[8:0]									000
60	3C	ADCOUT Drive	PCMTSEN	TRI	PCM8BIT	PUDOEN	PUDPE	PUDPS	LOUTR	PCMB	TSLOT[9:8]	020
<b>REGISTER ID</b>												
62	3E	Silicon Revision	0	1	1	1	0	1	1	1	1	0EF
63	3F	2-Wire ID	0	0	0	0	1	1	0	1	0	01A
64	40	Additional ID	0	1	1	0	0	1	0	1	0	0CA
65	41	Reserved	1	0	0	1	0	0	1	0	0	124
69	45	High Voltage CTRL	0	0	0	0	MOUTMT	0	HVOPU	0	HVOP	001
70	46	ALC Enhancements 1	ALCTBLSEL	ALCPKSEL	ALCNGSEL	ALCGAINL ( ONLY)					000	
71	47	ALC Enhancements 2	PKLIMEN	0	0	1	1	1	0	0	1	039
73	49	Additional IF CTRL	SPIEN	FSERRVAL[1:0]		FSERFLSH	FSERRENA	NFDLY	DACINMT	PLLLOCKP	DACOS256	000
75	4B	Power/Tie-off CTRL	0	LSPSKA	0	0	0	0	MANVREFH	MANVREFM	MANVREFL	000
76	4C	AGC P2P Detector	P2PDET ( ONLY)									000
77	4D	AGC Peak Detector	PDET ( ONLY)									000
78	4E	Control and Status	0	0	AMTCTRL	HVDET	NSGATE	AMUTE	DMUTE	0	FTDEC	000
79	4F	Output tie-off CTRL	MANOUTEN	SBUFH	SBUFL	SNSPK	SPSPK	SMOUT	0	0	0	000

## 13.1. SOFTWARE RESET

Addr	D8	D7	D6	D5	D4	D3	D2	D1	D0	Default
0x00	RESET (SOFTWARE)									0x000

This is device Reset register. Performing a write instruction to this register with any data will reset all the bits in the register map to default.

## 13.2. POWER MANAGEMENT REGISTERS

### 13.2.1. Power Management 1

Addr	D8	D7	D6	D5	D4	D3	D2	D1	D0	Default
0x01	DCBUFEN	0	AUXEN	PLLEN	MICBIASEN	ABIASEN	IOBUFEN	REFIMP[1:0]		0x000

Name	Buffer for DC level shifting Enable	AUX input buffer enable	PLL enable	Microphone Bias Enable	Analogue amplifier bias control	Unused input/output tie off buffer enable
Bit	DCBUFEN[8]	AUXEN[6]	PLLEN[5]	MICBIASEN[4]	ABIASEN[3]	IOBUFEN[2]
0	Disable	Disable	Disable	Disable	Disable	Disable
1	Enable (required for 1.5x gain)	Enable	Enable	Enable	Enable	Enable

The DCBUFEN[8] address (0x01) is a dedicated buffer for DC level shifting output stages when in 1.5x gain boost configuration. There are three different reference impedance selections to choose from as follows:

VREF REFERENCE IMPEDANCE SELECTION ("R" refers to "R" as shown in Figure3)		
REFIMP[1]	REFIMP[0]	Mode
0	0	Disable
0	1	R = 80 kΩ
1	0	R = 300 kΩ
1	1	R = 3 kΩ



### 13.2.2. Power Management 2

Addr	D8	D7	D6	D5	D4	D3	D2	D1	D0	Default
<b>0x02</b>	0	0	0	0	BSTEN	0	PGAEN	0	ADCEN	<b>0x000</b>

Name	Input Boost Enable	MIC(+/-) PGA Enable	ADC Enable
Bit	<b>BSTEN[4]</b>	<b>PGAEN[2]</b>	<b>ADCEN[0]</b>
0	Stage Disable	Disable	Disable
1	Stage Enable	Enable	Enable

### 13.2.3. Power Management 3

Addr	D8	D7	D6	D5	D4	D3	D2	D1	D0	Default
<b>0x03</b>	0	MOUTEN	NSPKEN	PSPKEN	0	MOUTMXEN	SPKMXEN	0	DACEN	<b>0x000</b>

Name	MOUT Enable	SPKOUT- Enable	SPKOUT+ Enable	MONO Mixer Enable	Speaker Mixer Enable	DAC Enable
Bit	<b>MOUTEN[7]</b>	<b>NSPKEN[6]</b>	<b>PSPKEN[5]</b>	<b>MOUTMXEN[3]</b>	<b>SPKMXEN[2]</b>	<b>DACEN[0]</b>
0	Disable	Disable	Disable	Disable	Disable	Disable
1	Enable	Enable	Enable	Enable	Enable	Enable

## 13.3. AUDIO CONTROL REGISTERS

### 13.3.1. Audio Interface Control

Addr	D8	D7	D6	D5	D4	D3	D2	D1	D0	Default
<b>0x04</b>	BCLKP	FSP	WLEN[1:0]		AIFMT[1:0]		DACPHS	ADCPHS	0	<b>0x050</b>

The following table explains the PCM control register bits.

Name	BCLK Polarity	Frame Clock Polarity	DAC Data 'right' or 'left' phases of FRAME clock	ADC Data 'right' or 'left' phases of FRAME clock
Bit	<b>BCLKP[8]</b>	<b>FSP[7]</b>	<b>DACPHS[2]</b>	<b>ADCPHS[1]</b>
0	Normal	Normal	DAC data appear in 'left' phase of FRAME	ADC data appear in 'left' phase of FRAME
1	Inverted	Inverted	DAC data appears in 'right' phase of FRAME	ADC data appears in 'right' phase of FRAME

There are three different CODEC modes to choose from as follows:

Word Length Selection		
WLEN[6]	WLEN[5]	Bits
0	0	16
0	1	20
1	0	24
1	1	32

Audio Data Format Select		
AIFMT[4]	AIFMT[3]	Format
0	0	Right Justified
0	1	Left Justified
1	0	I <sup>2</sup> S
1	1	PCM A

### 13.3.2. Audio Interface Companding Control

Addr	D8	D7	D6	D5	D4	D3	D2	D1	D0	Default
<b>0x05</b>	0	0	0	CMB8	DACCM[1:0]		ADCCM[1:0]		ADDAP	<b>0x000</b>

The NAU88C14 provides a Digital Loopback ADDAP[0] address (0x05) bit. Setting ADDAP[0] bit to HIGH enables the loopback so that the ADC data can be fed directly into the DAC input.

Companding Mode 8-bit word enable	
CMB8[5]	Mode
0	normal operation
1	8-bit operation

DAC Companding Selection		
DACCM[4]	DACCM[3]	Mode
0	0	Disabled
0	1	Reserved
1	0	μ-Law
1	1	A-Law

ADC Companding Select		
ADCCM[2]	ADCCM[1]	Mode
0	0	Disabled
0	1	Reserved
1	0	μ-Law
1	1	A-Law

### 13.3.3. Clock Control Register

Addr	D8	D7	D6	D5	D4	D3	D2	D1	D0	Default
<b>0x06</b>	CLKM	MCLKSEL[2:0]			BCLKSEL[2:0]			0	CLKIOEN	<b>0x140</b>

Master Clock Selection			
MCLKSEL [7]	MCLKSEL [6]	MCLKSEL [5]	Mode
0	0	0	÷ 1
0	0	1	÷ 1.5
0	1	0	÷ 2
0	1	1	÷ 3
1	0	0	÷ 4
1	0	1	÷ 6
1	1	0	÷ 8
1	1	1	÷ 12

Bit Clock Select			
BCLKSEL [4]	BCLKSEL [3]	BCLKSEL [2]	Mode
0	0	0	÷ 1 (BCLK=MCLK)
0	0	1	÷ 2 (BCLK=MCLK/2)
0	1	0	÷ 4
0	1	1	÷ 8
1	0	0	÷ 16
1	0	1	÷ 32
1	1	0	Reserved
1	1	1	Reserved

Name	Source of Internal Clock	FRAME and BCLK
Bit	CLKM[8]	CLKIOEN[0]
0	MCLK (PLL Bypassed)	Slave Mode
1	MCLK (PLL Output)	Master Mode

### 13.3.4. Audio Sample Rate Control Register

Addr	D8	D7	D6	D5	D4	D3	D2	D1	D0	Default
<b>0x07</b>	0	0	0	0	0	SMPLR[2:0]			SCLKEN	<b>0x000</b>

The Audio sample rate configures the coefficients for the internal digital filters

Sample Rate Selection			
SMPLR[3]	SMPLR[2]	SMPLR[1]	Mode (Hz)
0	0	0	48 k
0	0	1	32 k
0	1	0	24 k
0	1	1	16 k
1	0	0	12 k
1	0	1	8 k
1	1	0	Reserved
1	1	1	Reserved

NAU88C14 provides a slow clock to be used for both the jack insert detect debounce circuit and the zero cross timeout.

Bit	Slow Clock Enable
	<b>SCLKEN[0]</b>
0	MCLK
1	PLL Output (Period $2^{21} * \text{MCLK}$ )

### 13.3.5. GPIO Control Register

Addr	D8	D7	D6	D5	D4	D3	D2	D1	D0	Default
<b>0x08</b>	0	0	0	GPIOPLL[4:5]		GPIOPL	GPIOSEL[2:0]			<b>0x000</b>

General Purpose I/O Selection			
GPIOSEL [2]	GPIOSEL [1]	GPIOSEL [0]	Mode (Hz)
0	0	0	CSb Input
0	0	1	Jack Insert Detect
0	1	0	Temperature OK
0	1	1	AMUTE Active
1	0	0	PLL CLK Output
1	0	1	PLL Lock
1	1	0	1
1	1	1	0

PLL Output Clock Divider		
GPIOPLL[5]	GPIOPLL[4]	Mode
0	0	÷ 1
0	1	÷ 2
1	0	÷ 3
1	1	÷ 4

GPIO Polarity	
Bit	GPIOPL[3]
0	Normal
1	Inverted

### 13.3.6. DAC Control Register

Addr	D8	D7	D6	D5	D4	D3	D2	D1	D0	Default
<b>0x0A</b>	0	0	DACMT	DEEMP[1:0]		DACOS	AUTOMT	0	DACPL	<b>0x000</b>

Name	Soft Mute Enable	Over Sample Rate	Auto Mute enable	Polarity Invert
Bit	DACMT[6]	DACOS[3]	AUTOMT[2]	DACPL[0]
0	Disable	64x (Lowest power)	Disable	Normal
1	Enable	128x (best SNR)	Enable	DAC Output Inverted

De-emphasis		
DEEMP[5]	DEEMP[4]	Mode
0	0	No de-emphasis
0	1	32kHz sample rate
1	0	44.1kHz sample rate
1	1	48kHz sample rate

### 13.3.7. DAC Gain Control Register

Addr	D8	D7	D6	D5	D4	D3	D2	D1	D0	Default
0x0B	0	DACGAIN								0x0FF

DAC Gain								
DACGAIN[7:0]								Mode (dB)
B7	B6	B5	B4	B3	B2	B1	B0	
0	0	0	0	0	0	0	0	Digital Mute
0	0	0	0	0	0	0	1	-127.0
0	0	0	0	0	0	1	0	-126.5
0	0	0	0	0	0	1	1	-126.0
DAC Gain Range -127dB to 0dB @ 0.5 increments								
1	1	1	1	1	1	0	0	-1.5
1	1	1	1	1	1	0	1	-1.0
1	1	1	1	1	1	1	0	-0.5
1	1	1	1	1	1	1	1	0.0

### 13.3.8. ADC Control Register

Addr	D8	D7	D6	D5	D4	D3	D2	D1	D0	Default
0x0E	HPFEN	HPFAM	HPF[2:0]			ADCOS	0	0	ADCPL	0x100

Name	High Pass Filter Enable	Audio or Application Mode	Over Sample Rate	ADC Polarity
Bit	HPFEN[8]	HPFAM[7]	ADCOS[3]	ADCPL[0]
0	Disable	Audio (1 <sup>st</sup> order, $f_c \sim 3.7$ Hz)	64x (Lowest power)	Normal
1	Enable	Application (2 <sup>nd</sup> order, $f_c =$ HPF)	128x (best SNR)	Inverted

High Pass Filter			fs ( kHz)								
HPF[6]	HPF[5]	HPF[4]	SMPLR=101 SMPLR=100			SMPLR=011 SMPLR=010			SMPLR=001 SMPLR=000		
B2	B1	B0	8	11.025	12	16	22.05	24	32	44.1	48
0	0	0	82	113	122	82	113	122	82	113	122
0	0	1	102	141	153	102	141	153	102	141	153
0	1	0	131	180	156	131	180	156	131	180	156
0	1	1	163	225	245	163	225	245	163	225	245
1	0	0	204	281	306	204	281	306	204	281	306
1	0	1	261	360	392	261	360	392	261	360	392
1	1	0	327	450	490	327	450	490	327	450	490
1	1	1	408	563	612	408	563	612	408	563	612

### 13.3.9. ADC Gain Control Register

Addr	D8	D7	D6	D5	D4	D3	D2	D1	D0	Default
0x0F	0	ADCGAIN								0x0FF

ADC Gain								
ADCGAIN[7:0]								Mode (dB)
B7	B6	B5	B4	B3	B2	B1	B0	
0	0	0	0	0	0	0	0	Unused
0	0	0	0	0	0	0	1	-127.0
0	0	0	0	0	0	1	0	-126.5
0	0	0	0	0	0	1	1	-126.0
ADC Gain Range -127dB to 0dB @ 0.5 increments								
1	1	1	1	1	1	0	0	-1.5
1	1	1	1	1	1	0	1	-1.0
1	1	1	1	1	1	1	0	-0.5
1	1	1	1	1	1	1	1	0.0

### 13.4. 5-BAND EQUALIZER CONTROL REGISTERS

Address	D8	D7	D6	D5	D4	D3	D2	D1	D0	Default
0x12	EQM	0	EQ1CF[1:0]				EQ1GC[4:0]			0x12C
0x13	EQ2BW	0	EQ2CF[1:0]				EQ2GC[4:0]			0x02C
0x14	EQ3BW	0	EQ3CF[1:0]				EQ3GC[4:0]			0x 02C
0x15	EQ4BW	0	EQ4CF[1:0]				EQ4GC[4:0]			0x02C
0x16	0	0	EQ5CF[1:0]				EQ5GC[4:0]			0x02C

Equalizer Gain					
EQ1GC, EQ2GC, EQ3GC, EQ4GC, EQ5GC [4:0]					Mode (dB)
B4	B3	B2	B1	B0	
0	0	0	0	0	+12
0	0	0	0	1	+11
⋮	⋮	⋮	⋮	⋮	⋮
0	1	0	1	1	+1
0	1	1	0	0	0
0	1	1	0	1	-1
Equalizer Gain Range -12dB to +12dB @ 1.0 increment					
⋮	⋮	⋮	⋮	⋮	⋮
1	0	1	1	1	-11
1	1	0	0	0	-12
1	1	0	0	1	Reserved
To					
1	1	1	1	1	

		Center Frequencies		
B1	B0	EQ2CF[6:5]	EQ3CF[6:5]	EQ4CF[6:5]
0	0	230	650	1.8 k
0	1	300	850	2.4 k
1	0	385	1.1 k	3.2 k
1	1	500	1.4 k	4.1 k



		Cut-off Frequencies	
B1	B0	EQ1CF[6:5]	EQ5CF[6:5]
0	0	80	5.3 k
0	1	105	6.9 k
1	0	135	9.0 k
1	1	175	11.7 k

Bit	Bandwidth Control	Equalizer Path
	EQ2BW – EQ4BW	EQM[8]
0	Narrow bandwidth	ADC path
1	Wide bandwidth	DAC path

### 13.5. DIGITAL TO ANALOG CONVERTER (DAC) LIMITER REGISTERS

Addr	D8	D7	D6	D5	D4	D3	D2	D1	D0	Default
0x18	DACLIMEN	DACLIMDCY[3:0]				DACLIMATK[3:0]				0x032
0x19	0	0	DACLIMTHL[2:0]			DACLIMBST[3:0]				0x000

DAC Limiter Decay time (per 6dB gain change) for 44.1 kHz sampling. Note that these will scale with sample rate

DACLIMDCY[3:0]				Decay Time
B3	B2	B1	B0	
0	0	0	0	544.0 us
0	0	0	1	1.1 ms
0	0	1	0	2.2 ms
0	0	1	1	4.4 ms
0	1	0	0	8.7 ms
0	1	0	1	17.4 ms
0	1	1	0	35.0 ms
0	1	1	1	69.6 ms
1	0	0	0	139.0 ms
1	0	0	1	278.5 ms
1	0	1	0	557.0 ms
1	0	1	1	1.1 s
To				
1	1	1	1	

DAC Limiter Attack time (per 6dB gain change) for 44.1 kHz sampling. Note that these will scale with sample rate

DACLIMATK[3:0]				Attack Time
B3	B2	B1	B0	
0	0	0	0	68 us
0	0	0	1	136 us
0	0	1	0	272 us
0	0	1	1	544 us
0	1	0	0	1.1 ms
0	1	0	1	2.2 ms
0	1	1	0	4.4 ms
0	1	1	1	8.7 ms
1	0	0	0	17.4 ms
1	0	0	1	35 ms
1	0	1	0	69.6 ms
1	0	1	1	139 ms
To				
1	1	1	1	

DAC Limiter Programmable signal threshold level (determines level at which the limiter starts to operate)			
DACLIMTHL[3:0]			Threshold (dB)
B2	B1	B0	
0	0	0	-1
0	0	1	-2
0	1	0	-3
0	1	1	-4
1	0	0	-5
1	0	1	-6
To			
1	1	1	

DAC Digital Limiter	
Bit	DACLIMEN[8]
0	Disabled
1	Enabled

DAC Limiter volume Boost (can be used as a stand alone volume Boost when DACLIMEN=0)				
DACLIMBST[3:0]				Boost (dB)
B3	B2	B1	B0	
0	0	0	0	0
0	0	0	1	+1
0	0	1	0	+2
0	0	1	1	+3
0	1	0	0	+4
0	1	0	1	+5
0	1	1	0	+6
0	1	1	1	+7
1	0	0	0	+8
1	0	0	1	+9
1	0	1	0	+10
1	0	1	1	+11
1	1	0	0	+12
1	1	0	1	Reserved
To				
1	1	1	1	

### 13.6. NOTCH FILTER REGISTERS

Addr	D8	D7	D6	D5	D4	D3	D2	D1	D0	Default
<b>0x1B</b>	NFCU	NFCEN	NFCA0[13:7]							<b>0x000</b>
<b>0x1C</b>	NFCU	0	NFCA0[6:0]							<b>0x000</b>
<b>0x1D</b>	NFCU	0	NFCA1[13:7]							<b>0x000</b>
<b>0x1E</b>	NFCU	0	NFCA1[6:0]							<b>0x000</b>

The Notch Filter is enabled by setting NFCEN[7] address (0x1B) bit to HIGH. The coefficients,  $A_0$  and  $A_1$ , should be converted to 2's complement numbers to determine the register values.  $A_0$  and  $A_1$  are represented by the register bits NFCA0[13:0] and NFCA1[13:0]. Since there are four register of coefficients, a Notch Filter Update bit is provided so that the coefficients can be updated simultaneously. NFCU[8] is provided in all registers of the Notch Filter coefficients but only one bit needs to be toggled for LOW – HIGH – LOW for an update. If any of the NFCU[8] bits are left HIGH then the Notch Filter coefficients will continuously update. An example of how to calculate is provided in the Notch Filter section.

Name	$A_0$	$A_1$	Notation	Register Value (DEC)
Coefficient	$\frac{1 - \tan\left(\frac{2\pi f_b}{2f_s}\right)}{1 + \tan\left(\frac{2\pi f_b}{2f_s}\right)}$	$-(1 + A_0) \times \cos\left(\frac{2\pi f_c}{f_s}\right)$	$f_c$ = center frequency (Hz) $f_b$ = -3dB bandwidth (Hz) $f_s$ = sample frequency (Hz)	$NFCA0 = -A_0 \times 2^{13}$ $NFCA1 = -A_1 \times 2^{12}$ (then convert to 2's complement)

## 13.7. AUTOMATIC LEVEL CONTROL REGISTER

### 13.7.1. ALC1 REGISTER

Addr	D8	D7	D6	D5	D4	D3	D2	D1	D0	Default
0x20	ALCEN	0	0	ALCMXGAIN[2:0]			ALCMNGAIN[2:0]			0x038

Maximum Gain			
ALCMXGAIN[2:0]			Mode
B2	B1	B0	
0	0	0	-6.75dB
0	0	1	-0.75dB
0	1	0	+5.25dB
0	1	1	+11.25dB
1	0	0	+17.25dB
1	0	1	+23.25dB
1	1	0	+29.25dB
1	1	1	+35.25dB

Minimum Gain			
ALCMNGAIN[2:0]			Mode
B2	B1	B0	
0	0	0	-12dB
0	0	1	-6dB
0	1	0	0dB
0	1	1	+6dB
1	0	0	+12dB
1	0	1	+18dB
1	1	0	+24dB
1	1	1	+30dB

Name	ALC Enable
Bit	ALCEN[8]
0	Disabled (PGA gain set by PGAGAIN register bits)
1	Enabled (ALC controls PGA gain)

### 13.7.2. ALC2 REGISTER

Addr	D8	D7	D6	D5	D4	D3	D2	D1	D0	Default
0x21	ALCZC	ALCHT[3:0]			ALCSL[3:0]					0x00B

ALC HOLD TIME before gain is increased.				
ALCHT[3:0]				ALC Hold Time (sec)
B7	B6	B5	B4	
0	0	0	0	0
0	0	0	1	2 ms
0	0	1	0	4 ms
Time Doubles with every increment				
1	0	0	0	256 ms
1	0	0	1	512 ms
1	0	1	0	1 s
To				
1	1	1	1	

ALC TARGET – sets signal level at ADC input				
ALCSL[3:0]				ALC Target Level (dB)
B3	B2	B1	B0	
0	0	0	0	-28.5 fs
0	0	0	1	-27 fs
0	0	1	0	25.5 fs
ALC Target Level Range -28.5dB to -6dB @ 1.5dB increments				
1	0	1	1	-12 fs
1	1	0	0	-10.5 fs
1	1	0	1	-9 fs
1	1	1	0	-7.5 fs
1	1	1	1	-6 fs

Name	ALC Zero Crossing Detect
Bit	ALCZC[8]
0	Disabled
1	Enabled

It is recommended that zero crossing should not be used in conjunction with the ALC or Limiter functions

### 13.7.3. ALC3 REGISTER

Addr	D8	D7	D6	D5	D4	D3	D2	D1	D0	Default
0x22	ALCM	ALCDCY[3:0]				ALCATK[3:0]				0x032

ALC DECAY TIME									
ALCDCY[3:0]				ALCM = 0 (Normal Mode)			ALCM = 1 (Limiter Mode)		
B3	B2	B1	B0	Per Step	Per 6dB	90% of Range	Per Step	Per 6dB	90% of Range
0	0	0	0	500 us	4 ms	28.78 ms	125 us	1 ms	7.2 ms
0	0	0	1	1 ms	8 ms	57.56 ms	250 us	2 ms	14.4 ms
0	0	1	0	2 ms	16 ms	115 ms	500 us	4 ms	28.8 ms
Time doubles with every increment									
1	0	0	0	128 ms	1 s	7.37 s	32 ms	256 ms	1.8 s
1	0	0	1	256 ms	2 s	14.7 s	64 ms	512 ms	3.7 s
1	0	1	0	512 ms	4 s	29.5 s	128 ms	1 s	7.37 s
To									
1	1	1	1						

ALC ATTACK TIME									
ALCATK[3:0]				ALCM = 0 (Normal Mode)			ALCM = 1 (Limiter Mode)		
B3	B2	B1	B0	Per Step	Per 6dB	90% of Range	Per Step	Per 6dB	90% of Range
0	0	0	0	125 us	1 ms	7.2 ms	31 us	248 us	1.8 ms
0	0	0	1	250 us	2 ms	14.4 ms	62 us	496 us	3.6 ms
0	0	1	0	500 us	4 ms	28.85 ms	124 us	992 us	7.15 ms
Time doubles with every increment									
1	0	0	0	26.5 ms	256 ms	1.53 s	7.9 ms	63.2 ms	455.8 ms
1	0	0	1	53 ms	512 ms	3.06 s	15.87 ms	127 ms	916 ms
1	0	1	0	128 ms	1 s	7.89 s	31.7ms	254 ms	1.83 s
To									
1	1	1	1						

### 13.8. NOISE GAIN CONTROL REGISTER

Addr	D8	D7	D6	D5	D4	D3	D2	D1	D0	Default
<b>0x23</b>	0	0	0	0	0	ALCNEN	ALCNTH[2:0]			<b>0x000</b>

Noise Gate Enable	
Bit	ALCNEN[3]
0	Disabled
1	Enabled

Noise Gate Threshold			
ALCNTH[2:0]			Mode
B2	B1	B0	
0	0	0	-39 dB
0	0	1	-45 dB
0	1	0	-51 dB
0	1	1	-57 dB
1	0	0	-63 dB
1	0	1	-69 dB
1	1	0	-75 dB
1	1	1	-81 dB

### 13.9. PHASE LOCK LOOP (PLL) REGISTERS

#### 13.9.1. PLL Control Registers

Addr	D8	D7	D6	D5	D4	D3	D2	D1	D0	Default
0x24	0	0	0	0	PLLMCLK	PLLN[3:0]			0x008	

PLL Integer				
PLLN[3:0]				Frequency Ratio
B3	B2	B1	B0	
0	0	0	1	Not Valid
To				
0	1	0	0	5
0	1	0	1	
0	1	1	0	6
0	1	1	1	7
1	0	0	0	8
1	0	0	1	9
1	0	1	0	10
1	0	1	1	11
1	1	0	0	12
1	1	0	1	13
1	1	1	0	Not Valid
1	1	1	1	

PLL Clock	
Bit	PLLMCLK[4]
0	MCLK not divided
1	Divide MCLK by 2 before input PLL

#### 13.9.2. Phase Lock Loop Control (PLL) Registers

Addr	D8	D7	D6	D5	D4	D3	D2	D1	D0	Default
0x25	0	0	0	PLLK[23:18]						0x00C
0x26	PLLK[17:9]									0x093
0x27	PLLK[8:0]									0x0E9

Fractional (K) part of PLLK1 – PLLK3 input/output frequency ratio

## 13.10. INPUT, OUTPUT, AND MIXERS CONTROL REGISTER

### 13.10.1. Attenuation Control Register

Addr	D8	D7	D6	D5	D4	D3	D2	D1	D0	Default
<b>0x28</b>	0	0	0	0	0	0	MOUTATT	SPKATT	0	<b>0x000</b>

Attenuation Control			
Name	Attenuation control for bypass path (output of input boost stage) to speaker mixer and MONO mixer input		Microphone bias Mode selection
Bit	MOUTATT[2]	SPKATT[1]	MICBIASM[0]
0	0 dB	0 dB	Disable
1	-10 dB	-10 dB	Enable

### 13.10.2. Input Signal Control Register

Addr	D8	D7	D6	D5	D4	D3	D2	D1	D0	Default
<b>0x2C</b>	MICBIASV		0	0	0	AUXM	AUXPGA	NMICPGA	PMICPGA	<b>0x003</b>

Bit	AUXM[3]	AUXPGA[2]	NMICPGA[1]	PMICPGA[0]
0	Inverting Buffer	AUX not connected to input PGA	MICN not connected to input PGA	Input PGA Positive terminal to VREF
1	Mixer (Internal Resistor bypassed)	AUX to input PGA Negative terminal	MICN to input PGA Negative terminal.	Input PGA Positive terminal to MICP through variable resistor

Microphone Bias Voltage Control				
	MICBIASV[8:7] Address (0x2C)	MICBIASM[4] = 0 Address (0x28)	MICBIASM[4] = 1 Address (0x28)	
	0	0	0.9* VDDA	0.85* VDDA
	0	1	0.65* VDDA	0.60* VDDA
	1	0	0.75* VDDA	0.70* VDDA
	1	1	0.50* VDDA	0.50* VDDA



### 13.10.3. PGA Gain Control Register

Addr	D8	D7	D6	D5	D4	D3	D2	D1	D0	Default
<b>0x2D</b>	0	PGAZC	PGAMT	PGAGAIN[5:0]						<b>0x010</b>

Programmable Gain Amplifier Gain						
PGAGAIN[5:0]						Gain
B5	B4	B3	B2	B1	B0	
0	0	0	0	0	0	-12.00 dB
0	0	0	0	0	1	-11.25 dB
0	0	0	0	1	0	-10.50 dB
...	...	...	...	...	...	...
0	0	1	1	1	1	-0.75 dB
0	1	0	0	0	0	0 dB
0	1	0	0	0	1	+0.75 dB
PGA Gain Range -12dB to +35.25dB @ 0.75 increment						
...	...	...	...	...	...	...
1	1	1	1	0	1	33.75
1	1	1	1	1	0	34.50
1	1	1	1	1	1	35.25

Bit	PGA Zero Cross Enable	Mute Control for PGA
	PGAZC[7]	PGAMT[6]
0	Update gain when gain register changes	Normal Mode
1	Update gain on 1 <sup>st</sup> zero cross after gain register write	PGA Muted

### 13.10.4. ADC Boost Control Registers

Addr	D8	D7	D6	D5	D4	D3	D2	D1	D0	Default
<b>0x2F</b>	PGABST	0	PMICBSTGAIN			0	AUXBSTGAIN			<b>0x100</b>

MIC+ pin to the input Boost Stage (NB, when using this path set PMICPGA=0):			
PMICBSTGAIN[2:0]			Gain (dB)
B2	B1	B0	
0	0	0	Path Disconnected
0	0	1	-12
0	1	0	-9
0	1	1	-6
1	0	0	-3
1	0	1	0
1	1	0	+3
1	1	1	+6

Auxiliary to Input Boost Stage			
AUXBSTGAIN[2:0]			Gain (dB)
B2	B1	B0	
0	0	0	Path Disconnected
0	0	1	-12
0	1	0	-9
0	1	1	-6
1	0	0	-3
1	0	1	0
1	1	0	+3
1	1	1	+6

Name	Input Boost
Bit	PGABST[8]
0	PGA output has +0dB gain through input Boost stage
1	PGA output has +20dB gain through input Boost stage

### 13.10.5. Output Register

Addr	D8	D7	D6	D5	D4	D3	D2	D1	D0	Default
<b>0x31</b>	0	0	0	0	0	MOUTBST	SPKBST	TSEN	AOUTIMP	<b>0x002</b>

	MONO Output Boost Stage	Speaker Output Boost Stage	Thermal Shutdown	Analog Output Resistance
Bit	MOUTBST[3]	SPKBST[2]	TSEN[1]	AOUTIMP[0]
0	(1.0 x VREF) Gain Boost	(1.0 x VREF) Gain Boost	Disabled	~1kΩ
1	(1.5 x VREF) Gain Boost	(1.5 x VREF) Gain Boost	Enabled	~30 kΩ

### 13.10.6. Speaker Mixer Control Register

Addr	D8	D7	D6	D5	D4	D3	D2	D1	D0	Default
<b>0x32</b>	0	0	0	AUXSPK	0	0	0	BYSPK	DACSPK	<b>0x001</b>

	Auxiliary to Speaker Mixer	Bypass path (output of Boost stage) to Speaker Mixer	DAC to Speaker Mixer
Bit	AUXSPK[5]	BYSPK[1]	DACSPK[0]
0	Disconnected	Disconnected	Disconnected
1	Connected	Connected	Connected

### 13.10.7. Speaker Gain Control Register

Addr	D8	D7	D6	D5	D4	D3	D2	D1	D0	Default
<b>0x36</b>	0	SPKZC	SPKMT	SPKGAIN[5:0]						<b>0x039</b>

Speaker Gain						
SPKGAIN[5:0]						Gain (dB)
B5	B4	B3	B2	B1	B0	
0	0	0	0	0	0	-57.0
0	0	0	0	0	1	-56.0
0	0	0	0	1	0	-55.0
...	...	...	...	...	...	...
1	1	1	0	0	0	-1.0
1	1	1	0	0	1	0.0
1	1	1	0	1	0	+1.0
Speaker Gain Range -57 dB to +6 dB @ +1 increment						
...	...	...	...	...	...	...
1	1	1	1	0	1	+4.0
1	1	1	1	1	0	+5.0
1	1	1	1	1	1	+6.0

	Speaker Gain Control Zero Cross	Speaker Output
Bit	SPKZC[7]	SPKMT[6]
0	Change Gain on Zero Cross ONLY	Speaker Enabled
1	Change Gain Immediately	Speaker Muted

### 13.10.8. MONO Mixer Control Register

Addr	D8	D7	D6	D5	D4	D3	D2	D1	D0	Default
<b>0x38</b>	0	0	MOUTMXMT	0	0	0	AUXMOUT	BYPMOUT	DACMOUT	<b>0x001</b>

	MOUT Mute	Auxiliary to MONO Mixer	Bypass path (output of Boost Stage) to MONO Mixer	DAC to MONO Mixer
Bit	MOUTMXMT[6]	AUXMOUT[2]	BYPMOUT[1]	DACMOUT[0]
0	Not Muted	Disconnected	Disconnected	Disconnected
1	Muted	Connected	Connected	Connected

During mute, the MONO output will output VREF that can be used as a DC reference for a headphone out.

### 13.10.9. Power Management 4

Addr	D8	D7	D6	D5	D4	D3	D2	D1	D0	Default
<b>0x3A</b>	LPIPBST	LPADC	LPSPKD	LPDAC	MICBIASM	TRIMREG[3:2]		IBADJ[1:0]		<b>0x000</b>

B1	B0	Trim Output Regulator (V)	Adjust Master Bias of the Analog Portion
		TRIMREG[3:2]	IBADJ[1:0]
0	0	1.800	Default Current Consumption
0	1	1.610	25% Current Increase from Default
1	0	1.400	14% Current Decrease from Default
1	1	1.218	25% Current Decrease from Default

Trim regulator bits can be used only when VDDD < 2.7V.

	Low Power IP Boost	Low Power ADC	Low Power Speaker Driver	Low Power DAC	Microphone bias Mode selection
Bit	LPIPBST[8]	LPADC[7]	LPSPKD[6]	LPDAC[5]	MICBIASM[4]
0	Normal Function	Normal Function	Normal Function	Normal Function	Disable
1	Cut power in half	Cut power in half	Cut power in half	Cut power in half	Enable

Note cutting the power in half will directly affect the audio performances.

### 13.11. PCM TIME SLOT CONTROL & ADCOUT IMPEDANCE OPTION CONTROL

#### 13.11.1. PCM1 TIMESLOT CONTROL REGISTER

Addr	D8	D7	D6	D5	D4	D3	D2	D1	D0	Default
<b>0x3B</b>	TSLOT[8:0]									<b>0x000</b>

Transmit and receive timeslot are expressed in number of BCLK cycles in a 10-bit word. The most significant bit TSLOT[9] is located in register PCMTS2[0] address (0x3C). Timeslot, TSLOT[9:0], determines the start point for the timeslot on the PCM interface for data in the transmit direction.

#### 13.11.2. PCM2 TIMESLOT CONTROL REGISTER

Addr	D8	D7	D6	D5	D4	D3	D2	D1	D0	Default
<b>0x3C</b>	PCMTSEN	TRI	PCM8BIT	PUDOEN	PUDPE	PUDPS	LOUTR	PCMB	TSLOT[9]	<b>0x000</b>

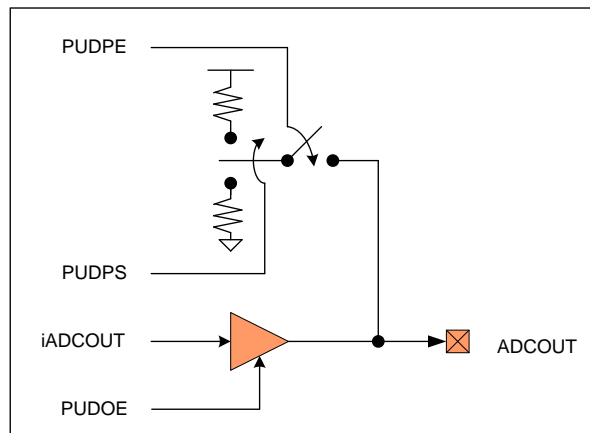

Name	PCM Transit Enable	Tri-state PCMT LSB	PCM Word Length	Left and Right Channel have same data	PCM Mode2
Bit	PCMTSEN[8]	TRI[7]	PCM8BIT[6]	LOUTR	PCMB
<b>0</b>	PCM A	Drive the full Clock of LSB	Use WLEN[6:5] to select Word Length	Disable	Disable
<b>1</b>	PCM Time Slot	Tri-State the 2 <sup>nd</sup> half of LSB	Audio interface will be 8 Bit Word Length	Enable	Enable

If TRI = 1 and PUDOEN = 0, the device will drive the LSB bit 1<sup>st</sup> half of BCLK out of the ADCOUT pin (stop driving after LSB BCLK Rising edge) but if TRI = 0 or PUDOEN = 1 this feature is disabled, full BCLK of LSB will be driven the LSB value.

Figure 39: The Programmable ADCOUT Pin

Internal ADC out data	Power Up and Down Output Enable	Power Up and Down Pull Enable	Power Up and Down Pull Select	OUTPUT
iADCOUT	PUDOEN[5]	PUDPE[4]	PUDPS[3]	PAD
0	1	x	x	0
1	1	x	x	1
x	0	0	x	Hi-Z
x	0	1	0	Pull-Low
x	0	1	1	Pull-High

### 13.12. REGISTER ID

#### 13.12.1. Device revision register

Addr	D8	D7	D6	D5	D4	D3	D2	D1	D0	Default
<b>0x3E</b>	0	1	1	1	0	1	1	1	0	<b>0x0EF</b>

Device revision ID

#### 13.12.2. 2-WIRE ID Register

Addr	D8	D7	D6	D5	D4	D3	D2	D1	D0	Default
<b>0x3F</b>	0	0	0	0	1	1	0	1	0	<b>0x01A</b>

First 7 bits (D0 – D6) of the 2-Wire device ID excluding the LSB /write bit.

#### 13.12.3. Additional ID

Addr	D8	D7	D6	D5	D4	D3	D2	D1	D0	Default
<b>0x40</b>	0	1	1	0	0	1	0	1	0	<b>0x0CA</b>

ONLY

### 13.13. Reserved

Addr	D8	D7	D6	D5	D4	D3	D2	D1	D0	Default
<b>0x41</b>	1	0	0	1	0	0	1	0	0	<b>0x124</b>

### 13.14. OUTPUT Driver Control Register

Addr	D8	D7	D6	D5	D4	D3	D2	D1	D0	Default
0x45	0				MOUTMT	0	HVOPU	0	HVOP	0x001

Bit Location	Bit Description	Bit Name	Bit Value	
			0	1
0	Override to automatic 3V/5V bias selection	HVOP	set internal output biasing to be optimal for 3.6Vdc or lower operation <b>Note: For this to be effective HVOPU[2] address 0x45 must set</b>	set internal output biasing to be optimal for higher than 3.6Vdc operation <b>Note: For this to be effective HVOPU[2] address 0x45 must set</b>
2	Update bit for HV override feature	HVOPU	High Voltage override Disable	This bit must set in conjunction with HVOP[0] address 0x45 for the automatic override to be effective
4	Headphone output mute	MOUTMT	Disable	Enable

During mute, the MONO output will output VREF that can be used as a DC reference for a headphone out.

### 13.15. AUTOMATIC LEVEL CONTROL ENHANCED REGISTER

#### 13.15.1. ALC1 Enhanced Register

Addr	D8	D7	D6	D5	D4	D3	D2	D1	D0	Default
<b>0x46</b>	ALCTBLSEL	ALCPKSEL	ALCNGSEL	ALCGAIN ( ONLY)						<b>0x001</b>

Bit Location	Bit Description	Bit Name	Bit Value	
			0	1
6	Selects one of two tables used to set the target level for the ALC	<b>ALCNGSEL</b>	default recommended target level table spanning -1.5dB through -22.5dB FS	optional ALC target level table spanning -6.0dB through -28.5dB FS
7	Choose peak or peak-to-peak value for ALC threshold logic	<b>ALCPKSEL</b>	use rectified peak detector output value	use peak-to-peak detector output value
8	Choose peak or peak-to-peak value for Noise Gate threshold logic	<b>ALCTBLSEL</b>	use rectified peak detector output value	use peak-to-peak detector output value

#### 13.15.2. ALC Enhanced 2 Register

Addr	D8	D7	D6	D5	D4	D3	D2	D1	D0	Default
<b>0x47</b>	PKLIMEN	0								<b>0x000</b>

Bit Location	Bit Description	Bit Name	Bit Value	
			0	1
8	Enable control for ALC fast peak limiter function	<b>PKLIMEN</b>	Enable	Disable



### 13.16. MISC CONTROL REGISTER

Addr	D8	D7	D6	D5	D4	D3	D2	D1	D0	Default
<b>0x49</b>	SPIEN	FSERRVAL[1:0]	FSERFLSH	FSERRENA	NFDLY	DACINMT	PLLLOCKP	DACOS256	<b>0x000</b>	

Bit Location	Bit Description	Bit Name	Bit Value	
			0	1
0	Set DAC to use 256x oversampling rate	<b>DACOS256</b>	Use oversampling rate as determined by Register 0x0A[3] (default)	Set DAC to 256x oversampling rate regardless of Register 0x0A[3]
1	Enable control to use PLL output when PLL is not in phase locked condition	<b>PLLLOCKP</b>	PLL VCO output disabled when PLL is in unlocked condition (default)	PLL VCO output used as-is when PLL is in unlocked condition
2	Enable control to mute DAC limiter output when softmute is enabled	<b>DACINMT</b>	DAC limiter output may not move to exactly zero during Softmute (default)	DAC limiter output muted to exactly zero during Softmute
3	Enable control to delay use of notch filter output when filter is enabled	<b>NFDLY</b>	Delay using notch filter output 512 sample times after notch enabled (default)	Use notch filter output immediately after notch filter is enabled
4	Enable control for short frame cycle detection logic	<b>FSERRENA</b>	Short frame cycle detection logic enabled	Short frame cycle detection logic disabled
5	Enable DSP state flush on short frame sync event	<b>FSERFLSH</b>	Ignore short frame sync events (default)	Set DSP state to initial conditions on short frame sync event
8	Set SPI control bus mode regardless of state of Mode pin	<b>SPIEN</b>	Default Operation	force SPI 4-wire mode regardless of state of Mode pin

B1	B0	Short frame sync detection period value trigger if frame time less than <b>FSERRVAL[1:0]</b>
0	0	255 MCLK edges
0	1	253 MCLK edges
1	0	254 MCLK edges
1	1	255 MCLK edges

MODE Pin	SPIEN[8] Bit	Address	Description
0	0	0x49	2-Wire Interface (Write/)
1	0		SPI Interface 16-bit (Write ONLY)
x	1		SPI Interface 24-bit (Write)

### 13.17. Output Tie-Off REGISTER

Addr	D8	D7	D6	D5	D4	D3	D2	D1	D0	Default
0x4B	0	LPSPKA					MANVREFH	MANVREFM	MANVREFL	0x000

Bit Location	Bit Description	Bit Name	Bit Value	
			0	1
0	Direct manual control for switch for VREF 6k-ohm resistor to ground	MANVREFL	switch to ground controlled by Register 0x01 setting	switch to ground in the closed position
1	Direct manual control for switch for VREF 160k-ohm resistor to ground	MANVREFM	switch to ground controlled by Register 0x01 setting	switch to ground in the closed position
2	Direct manual control of switch for VREF 600k-ohm resistor to ground	MANVREFH	switch to ground controlled by Register 0x01 setting	switch to ground in the closed position
7	Amplifier Stage	LPSPKA	Two-stage amplifier for speaker driver	Three-stage amplifier for speaker driver

### 13.18. AGC PEAK-TO-PEAK OUT REGISTER

Addr	D8	D7	D6	D5	D4	D3	D2	D1	D0	Default
0x4C	P2PDET									0x000

Bit Location	Bit Description	Bit Name
0 – 8	ONLY Register Outputs the instantaneous value contained in the peak-to-peak amplitude register used by the ALC for signal level dependent logic. Value is highest of left or right input when both inputs are under ALC control.	P2PDET

### 13.19. AGC PEAK OUT REGISTER

Addr	D8	D7	D6	D5	D4	D3	D2	D1	D0	Default
0x4D	PDET									0x000

Bit Location	Bit Description	Bit Name
0 – 8	ONLY Register Outputs the instantaneous value contained in the peak detector amplitude register used by the ALC for signal level dependent logic. Value is highest of left or right input when both inputs are under ALC control.	PDET

### 13.20. AUTOMUTE CONTROL AND STATUS REGISTER

Addr	D8	D7	D6	D5	D4	D3	D2	D1	D0	Default
<b>0x4E</b>	0	0	AMTCTRL	HVDET	NSGATE	AMUTE	DMUTE	0	FTDEC	<b>0x000</b>

Bit Location	Bit Description	Bit Name	Bit Value	
			0	1
0	Peak limiter indicator	<b>FASTDEC</b>	Below 87.5% of full scale	Above 87.5% of full scale
2	<b>ONLY BIT</b> Digital Mute function of the DAC	<b>DMUTE</b>	Digital gain greater than zero	Digital gain is zero either by - Direct setting - Softmute function
3	<b>ONLY BIT</b> Analog Mute function applied to DAC	<b>AMUTE</b>	Automute Disabled	Automute Enabled
4	<b>ONLY BIT</b> Logic controlling the Noise Gate	<b>NSGATE</b>	Signal is greater than the noise gate threshold and ALC gain can change	Signal is less than the noise gate threshold and ALC gain is held constant
5	<b>ONLY BIT</b> High voltage detection circuit monitoring VDDSPK voltage	<b>HVDET</b>	VDDSPK logic switch voltage threshold measured as 4.0Vdc or Less	VDDSPK logic switch voltage threshold measured as 4.0Vdc or Greater
6	Select observation point used by DAC output Automute feature	<b>AMTCTRL</b>	Automute operates on data at the input to the DAC digital attenuator (default)	Automute operates on data at the DACIN input pin

### 13.21. Output Tie-off Direct Manual Control REGISTER

Addr	D8	D7	D6	D5	D4	D3	D2	D1	D0	Default
<b>0x4F</b>	MANOUTEN	SBUFH	SBUFL	SNSPK	SPSPK	SMOUT	0	0	0	<b>0x000</b>

Bit Location	Bit Description	Bit Name	Bit Value	
			0	1
3	If MANUOUTEN = 1, use this bit to control Auxout1 output tie-off resistor switch	<b>SMOUT</b>	Tie-off resistor switch for MOUT output is forced open	Tie-off resistor switch for MOUT output is forced closed
4	If MANUOUTEN = 1, use this bit to control left speaker output Tie-off resistor switch	<b>SPSPK</b>	Tie-off resistor switch for SPKOUTP speaker output is forced open	Tie-off resistor switch for SPKOUTP speaker output is forced closed
5	If MANUOUTEN = 1, use this bit to control left speaker output Tie-off resistor switch	<b>SNSPK</b>	Tie-off resistor switch for SPKOUTN speaker output is forced open	Tie-off resistor switch for SPKOUTN speaker output is forced closed
6	If MANUOUTEN = 1, use this bit to control bypass switch around 1.0x non-boosted output Tie-off buffer amplifier	<b>SBUFL</b>	Normal automatic operation of bypass switch	Bypass switch in closed position when output buffer amplifier is disabled
7	If MANUOUTEN = 1, use this bit to control bypass switch around 1.5x boosted output Tie-off buffer amplifier	<b>SBUFH</b>	Normal automatic operation of bypass switch	Bypass switch in closed position when output buffer amplifier is disabled
8	Enable direct control over output Tie-off resistor switching	<b>MANOUTEN</b>	Ignore Register 0x4F bits to control input Tie-off resistor/buffer switching	Use Register 0x4F bits to override automatic Tie-off resistor/buffer switching

## 14. CONTROL INTERFACE TIMING DIAGRAM

### 14.1. SPI WRITE TIMING DIAGRAM

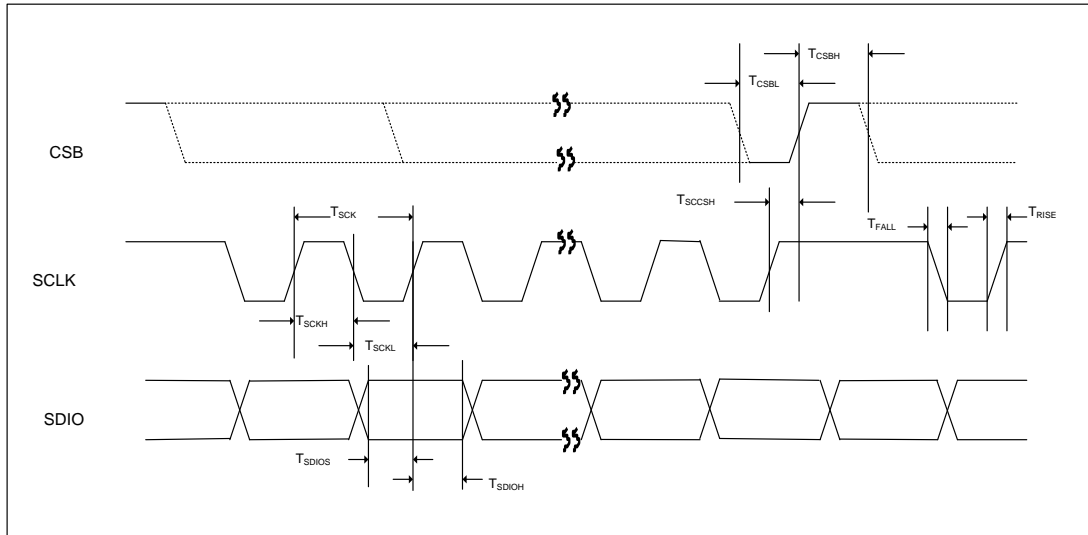

Figure 40: SPI Write Timing Diagram

SYMBOL	DESCRIPTION	MIN	TYP	MAX	UNIT
$T_{SCK}$	SCLK Cycle Time	80	---	---	ns
$T_{SCKH}$	SCLK High Pulse Width	35	---	---	ns
$T_{SCKL}$	SCLK Low Pulse Width	35	---	---	ns
$T_{RISE}$	Rise Time for all SPI Signals	---	---	10	ns
$T_{FALL}$	Fall Time for all SPI Signals	---	---	10	ns
$T_{CSSCS}$	CSb Falling Edge to 1 <sup>st</sup> SCLK Falling Edge Setup Time (4 wire SPI only)	30	---	---	ns
$T_{SCCSH}$	Last SCLK Rising Edge to CSb Rising Edge Hold Time	30	---	---	ns
$T_{CSBL}$	CSb Low Time	30	---	---	ns
$T_{CSBH}$	CSb High Time between CSb Lows	30	---	---	ns
$T_{SDIOS}$	SDIO to SCLK Rising Edge Setup Time	20	---	---	ns
$T_{SDIOH}$	SCLK Rising Edge to SDIO Hold Time	20	---	---	ns

Table 35: SPI Timing Parameters

## 14.2. 2-WIRE TIMING DIAGRAM

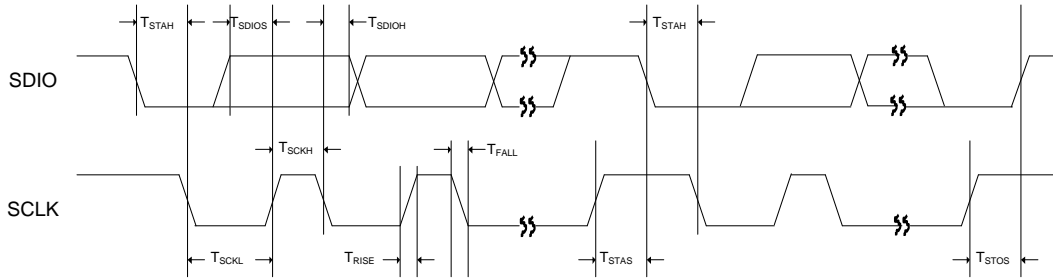

Figure 41: 2-Wire Timing Diagram

SYMBOL	DESCRIPTION	MIN	TYP	MAX	UNIT
$T_{STAH}$	START / Repeat START condition, SCLK falling edge to SDIO falling edge hold timing	600	---	---	ns
$T_{STAS}$	Repeat START condition, SDIO rising edge to SCLK falling edge setup timing	600	---	---	ns
$T_{STOS}$	STOP condition, SDIO rising edge to SCLK rising edge setup timing	600	---	---	ns
$T_{SCKH}$	SCLK High Pulse Width	600	---	---	ns
$T_{SCKL}$	SCLK Low Pulse Width	1.3	---	---	us
$T_{RISE}$	Rise Time for all 2-Wire Signals	---	---	300	ns
$T_{FALL}$	Fall Time for all 2-Wire Signals	---	---	300	ns
$T_{SDIOS}$	SDIO to SCLK Rising Edge DATA Setup Time	400	---	---	ns
$T_{SDIOH}$	SCLK falling Edge to SDIO DATA Hold Time	0	---	600	ns

Table 36: 2-Wire Timing Parameters

15. AUDIO INTERFACE TIMING DIAGRAM

15.1. AUDIO INTERFACE IN SLAVE MODE

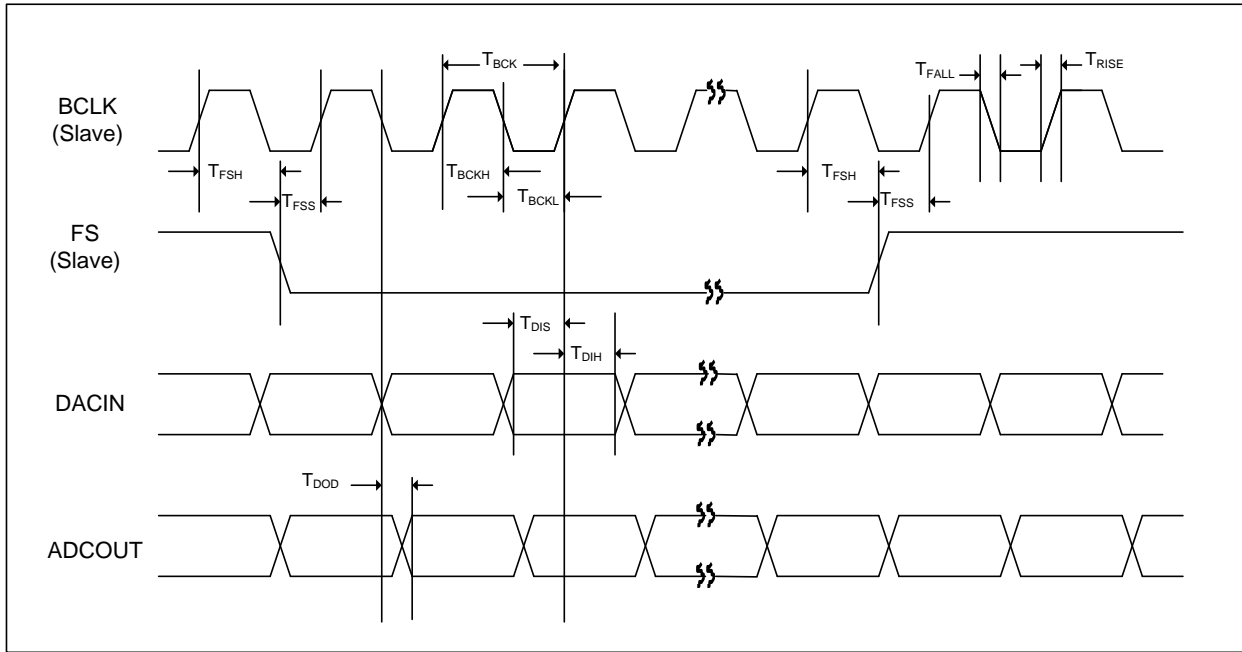

Figure 42: Audio Interface Slave Mode Timing Diagram

15.2. AUDIO INTERFACE IN MASTER MODE

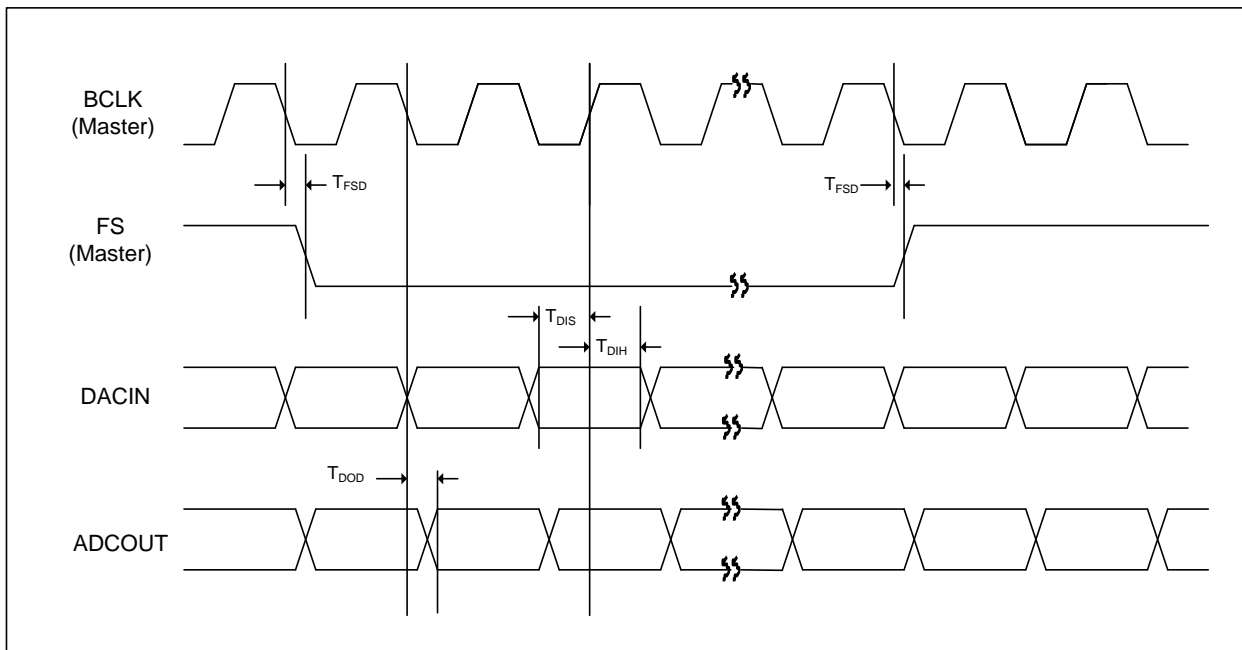

Figure 43: Audio Interface in Master Mode Timing Diagram

15.3. PCM AUDIO INTERFACE IN SLAVE MODE (PCM Audio Data)

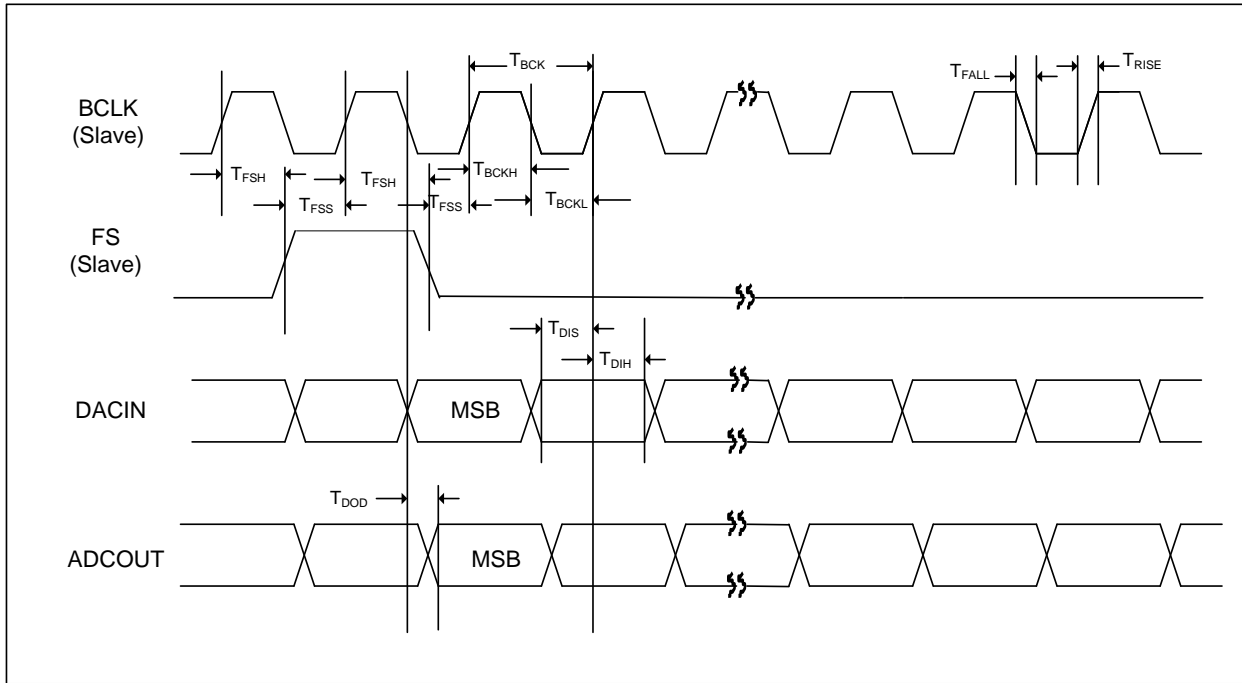

Figure 44: PCM Audio Interface Slave Mode Timing Diagram

15.4. PCM AUDIO INTERFACE IN MASTER MODE (PCM Audio Data)

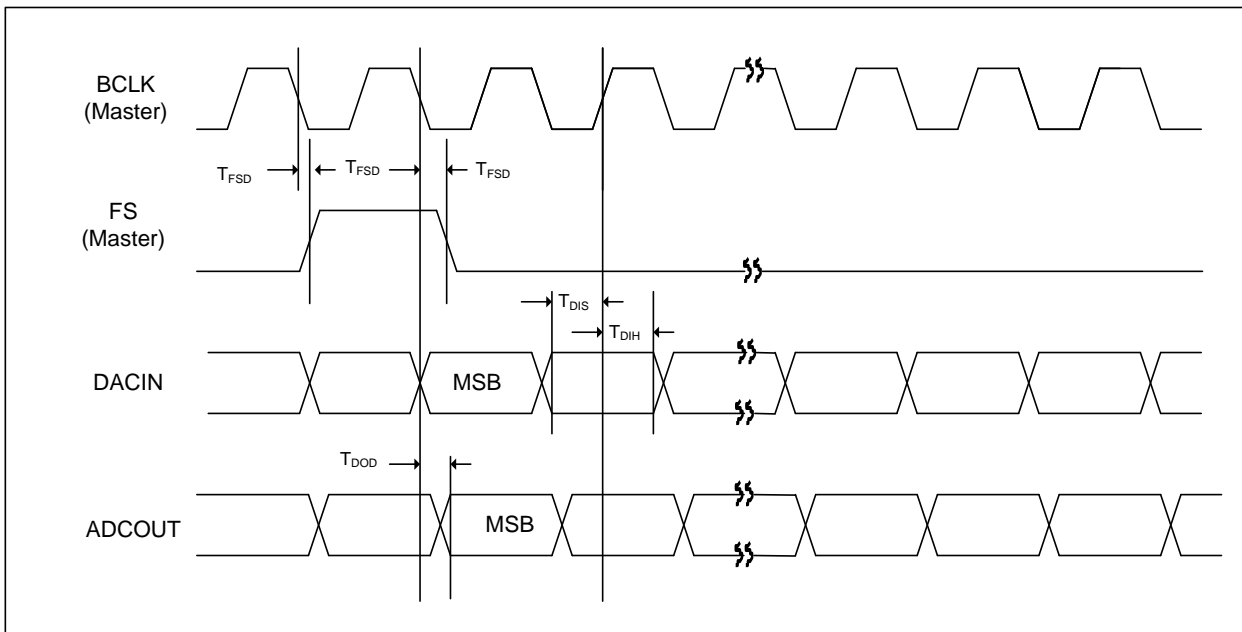

Figure 45: PCM Audio Interface Slave Mode Timing Diagram

15.5. PCM AUDIO INTERFACE IN SLAVE MODE (PCM Time Slot Mode )

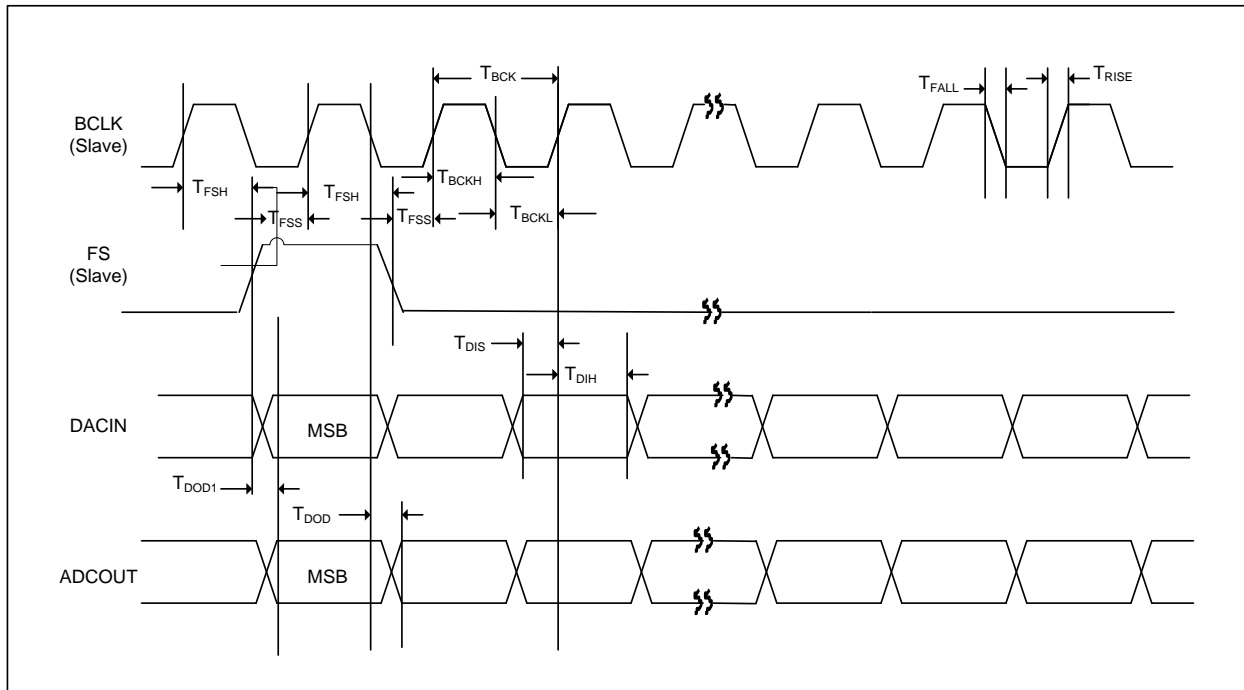

Figure 46: PCM Audio Interface Slave Mode (PCM Time Slot Mode )Timing Diagram

15.6. PCM AUDIO INTERFACE IN MASTER MODE (PCM Time Slot Mode )

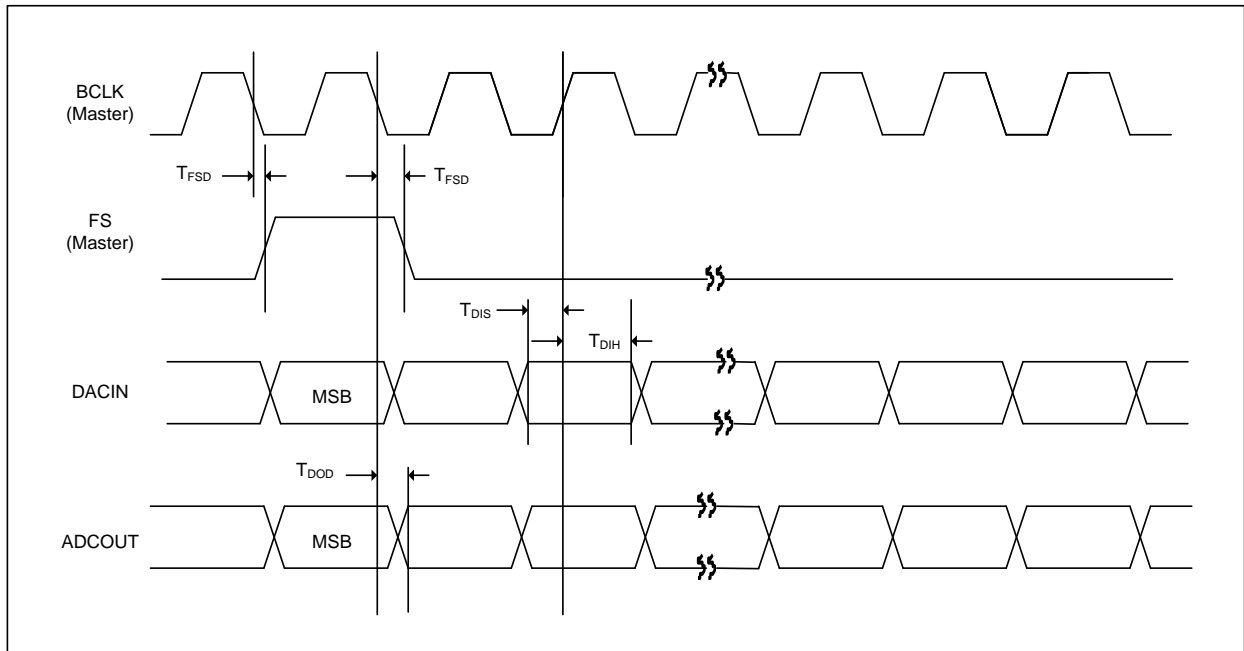

Figure 47: PCM Audio Interface Master Mode (PCM Time Slot Mode )Timing Diagram



SYMBOL	DESCRIPTION	MIN	TYP	MAX	UNIT
$T_{BCK}$	BCK Cycle Time (Slave Mode)	50	---	---	ns
$T_{BCKH}$	BCK High Pulse Width (Slave Mode)	20	---	---	ns
$T_{BCKL}$	BCK Low Pulse Width (Slave Mode)	20	---	---	ns
$T_{FSS}$	fs to SCK Rising Edge Setup Time (Slave Mode)	20	---	---	ns
$T_{FSH}$	SCK Rising Edge to fs Hold Time (Slave Mode)	20	---	---	ns
$T_{FSD}$	fs to SCK falling to fs transition (Master Mode)	---	---	10	ns
$T_{RISE}$	Rise Time for All Audio Interface Signals	---	---	$0.135T_{BCK}$	ns
$T_{FALL}$	Fall Time for All Audio Interface Signals	---	---	$0.135T_{BCK}$	ns
$T_{DIS}$	ADCIN to SCK Rising Edge Setup Time	15	---	---	ns
$T_{DIH}$	SCK Rising Edge to ADCIN Hold Time	15	---	---	ns
$T_{DOD}$	Delay Time from SCLK falling Edge to DACOUT (Master Node)	---	---	20	ns
	Delay Time from SCLK falling Edge to DACOUT (Slave Node)	---	---	30	ns

Table 37: Audio Interface Timing Parameters

### 15.7. System Clock (MCLK) Timing Diagram

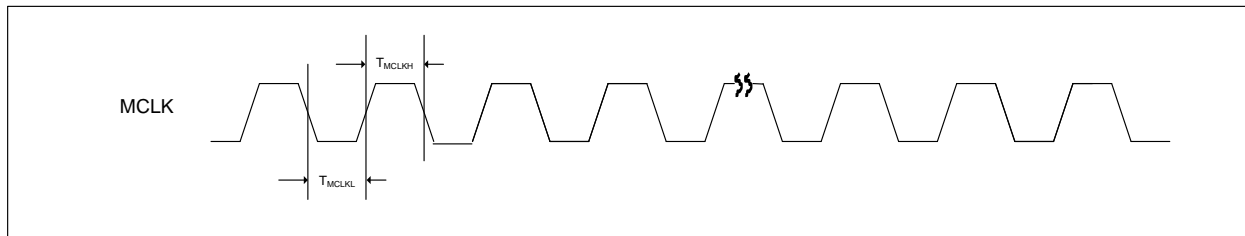

Figure 48: MCLK Timing Diagram

PARAMETER	SYMBOL	TEST CONDITIONS	MIN	TYP	MAX	UNIT
MCLK Duty Cycle	$T_{MCLKDC}$		60:40		40:60	
MCLK High Pulse Width	$T_{MCLKH}$		20	---	---	ns
MCLK Low Pulse Width	$T_{MCLKL}$		20	---	---	ns

Table 38: MCLK Timing Parameter

### 15.8. $\mu$ -LAW ENCODE DECODE CHARACTERISTICS

Normalized Encode Decision Levels	Digital Code								Normalized Decode Levels	
	D7	D6	D5	D4	D3	D2	D1	D0		
	Sign	Chord	Chord	Chord	Step	Step	Step	Step		
8159										
	1	0	0	0	0	0	0	0	8031	
7903	:	:	:	:	:	:	:	:	:	
4319										
	1	0	0	0	1	1	1	1	4191	
4063	:	:	:	:	:	:	:	:	:	
2143										
	1	0	0	1	1	1	1	1	2079	
2015	:	:	:	:	:	:	:	:	:	
1055										
	1	0	1	0	1	1	1	1	1023	
991	:	:	:	:	:	:	:	:	:	
511										
	1	0	1	1	1	1	1	1	495	
479	:	:	:	:	:	:	:	:	:	
239										
	1	1	0	0	1	1	1	1	231	
223	:	:	:	:	:	:	:	:	:	
103										
	1	1	0	1	1	1	1	1	99	
95	:	:	:	:	:	:	:	:	:	
35										
	1	1	1	0	1	1	1	1	33	
31	:	:	:	:	:	:	:	:	:	
3										
	1	1	1	1	1	1	1	0	2	
1	:	:	:	:	:	:	:	:	:	
	1	1	1	1	1	1	1	1	0	
0										

Notes:  
Sign bit = 0 for negative values, sign bit = 1 for positive values

## 15.9. A-LAW ENCODE DECODE CHARACTERISTICS

Normalized Encode Decision Levels	Digital Code								Normalized Decode Levels
	D7	D6	D5	D4	D3	D2	D1	D0	
	Sign	Chord	Chord	Chord	Step	Step	Step	Step	
4096	1	0	1	0	1	0	1	0	4032
3968	:	:	:	:	:	:	:	:	:
2176	1	0	1	0	0	1	0	1	2112
2048	:	:	:	:	:	:	:	:	:
1088	1	0	1	1	0	1	0	1	1056
1024	:	:	:	:	:	:	:	:	:
544	1	0	0	0	0	1	0	1	528
512	:	:	:	:	:	:	:	:	:
272	1	0	0	1	0	1	0	1	264
256	:	:	:	:	:	:	:	:	:
136	1	1	1	0	0	1	0	1	132
128	:	:	:	:	:	:	:	:	:
68	1	1	1	0	0	1	0	1	66
64	:	:	:	:	:	:	:	:	:
2	1	1	0	1	0	1	0	1	1
0									

Notes:

1. Sign bit = 0 for negative values, sign bit = 1 for positive values
2. Digital code includes inversion of all even number bits

### 15.10. $\mu$ -LAW / A-LAW CODES FOR ZERO AND FULL SCALE

Level	$\mu$ -Law			A-Law		
	Sign bit (D7)	Chord bits (D6,D5,D4)	Step bits (D3,D2,D1,D0)	Sign bit (D7)	Chord bits (D6,D5,D4)	Step bits (D3,D2,D1,D0)
+ Full Scale	1	000	0000	1	010	1010
+ Zero	1	111	1111	1	101	0101
- Zero	0	111	1111	0	101	0101
- Full Scale	0	000	0000	0	010	1010

### 15.11. $\mu$ -LAW / A-LAW OUTPUT CODES (DIGITAL MW)

Sample	$\mu$ -Law			A-Law		
	Sign bit (D7)	Chord bits (D6,D5,D4)	Step bits (D3,D2,D1,D0)	Sign bit (D7)	Chord bits (D6,D5,D4)	Step bits (D3,D2,D1,D0)
1	0	001	1110	0	011	0100
2	0	000	1011	0	010	0001
3	0	000	1011	0	010	0001
4	0	001	1110	0	011	0100
5	1	001	1110	1	011	0100
6	1	000	1011	1	010	0001
7	1	000	1011	1	010	0001
8	1	001	1110	1	011	0100

## 16. DIGITAL FILTER CHARACTERISTICS

PARAMETER	TEST CONDITIONS	MIN	TYP	MAX	UNIT
<b>ADC Filter</b>					
Passband	+/- 0.025dB	0		0.454*fs	
	-6dB		0.5*fs		
Passband Ripple				+/-0.025	dB
Stopband		0.546*fs			
Stopband Attenuation	f > 0.546*fs	-60			dB
Group Delay			21/fs		

<b>ADC High Pass Filter</b>					
High Pass Filter Corner Frequency	-3dB		3.7		Hz
	-0.5dB		10.4		
	-0.1dB		21.6		

<b>DAC Filter</b>					
Passband	+/- 0.035dB	0		0.454*fs	
	-6dB		0.5*fs		
Passband Ripple				+/-0.035	dB
Stopband		0.546*fs			
Stopband Attenuation	f > 0.546*fs	-55			dB
Group Delay			29/fs		

Table 57 Digital Filter Characteristics

### TERMINOLOGY

1. Stop Band Attenuation (dB) – the degree to which the frequency spectrum is attenuated (outside audio band)
2. Pass-band Ripple – any variation of the frequency response in the pass-band region
3. Note that this delay applies only to the filters and does not include

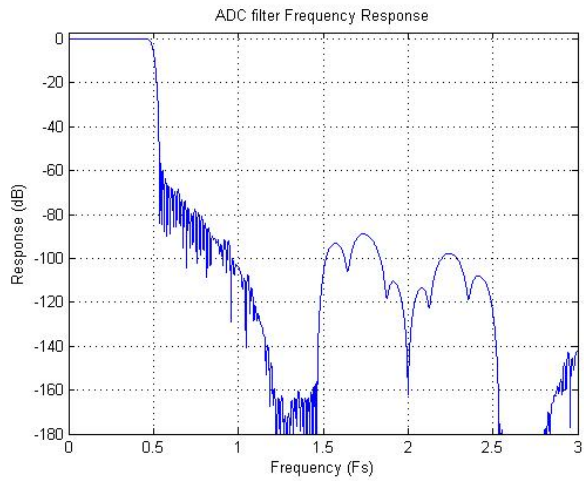

Figure 49: DAC Filter Frequency Response

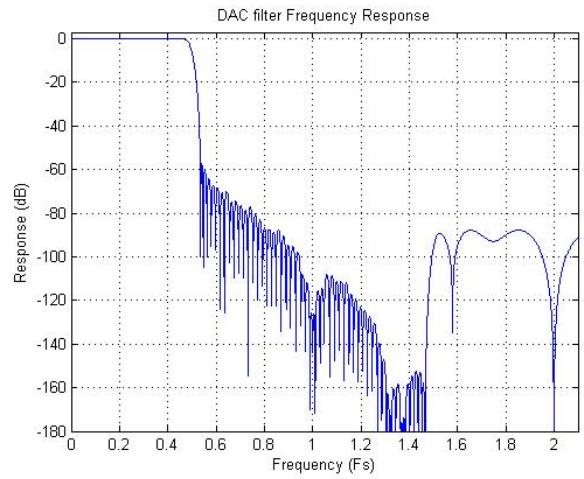

Figure 50: ADC Filter Frequency Response

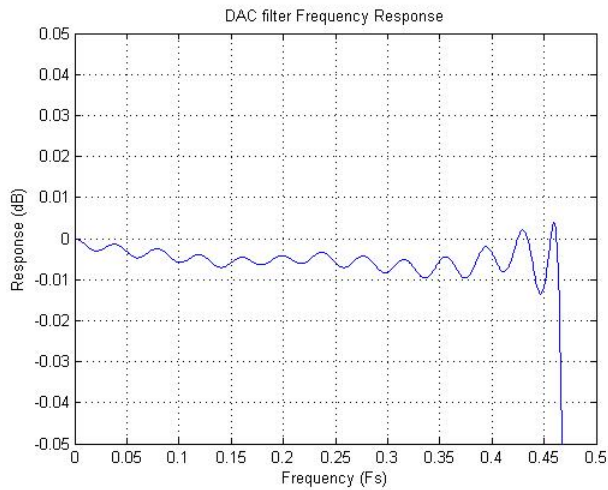

Figure 51: DAC Filter Ripple

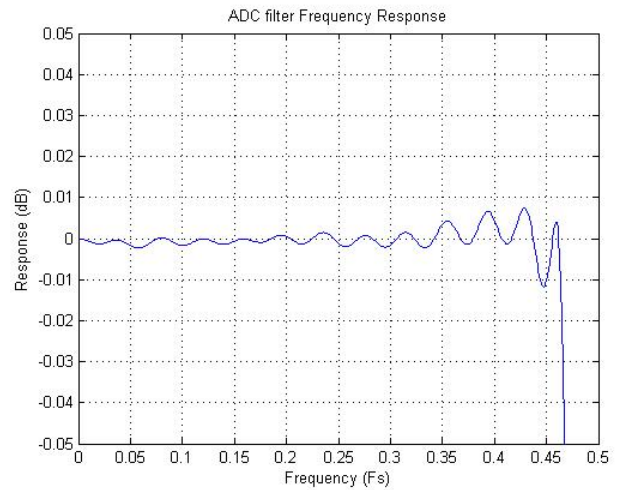

Figure 52: ADC Filter Ripple

## 17. TYPICAL APPLICATION

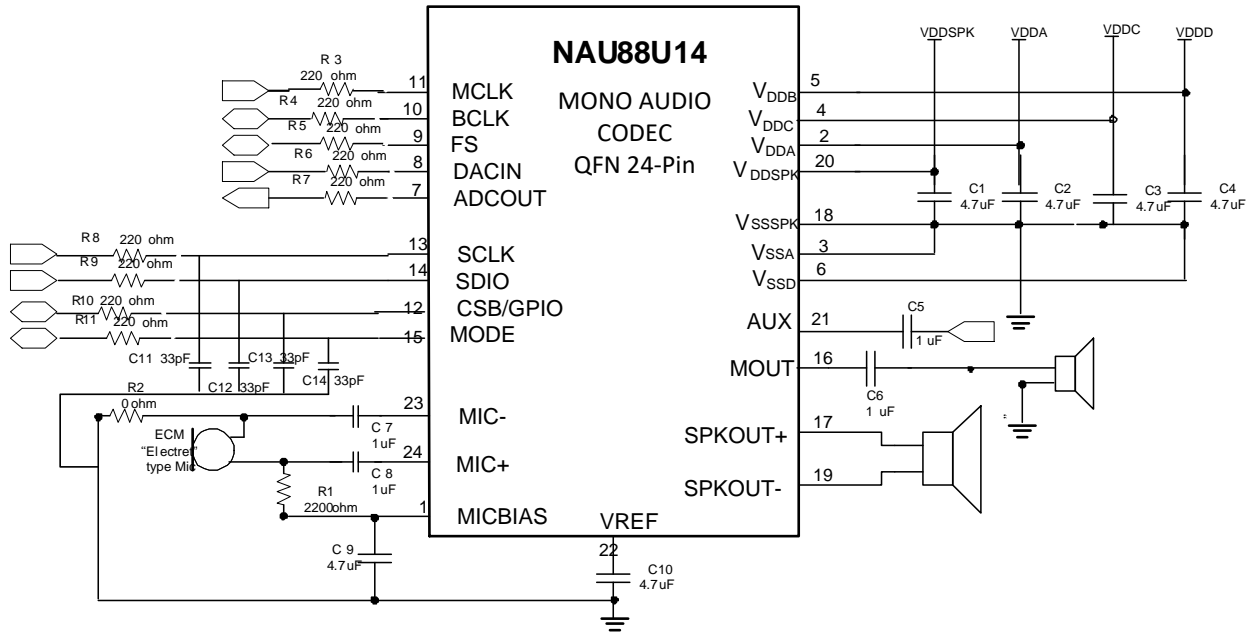
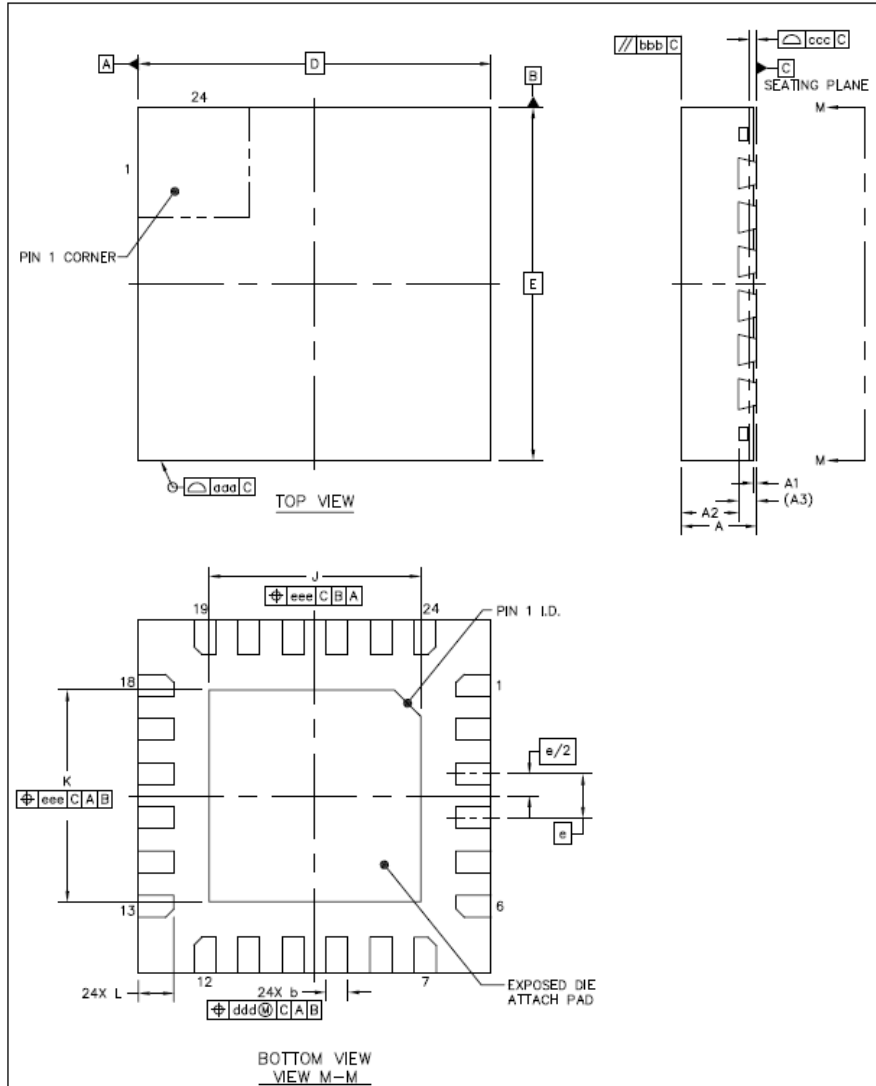

Figure 53: Application Diagram For 24-Pin QFN

- Note 1: All non-polar capacitors are assumed to be low ESR type parts, such as with MLC construction or similar. If capacitors are not low ESR, additional 0.1uF and/or 0.01uF capacitors may be necessary in parallel with the bulk 4.7uF capacitors on the supply rails.
- Note 2: Load resistors to ground on outputs may be helpful in some applications to insure a DC path for the output capacitors to charge/discharge to the desired levels. If the output load is always present and the output load provides a suitable DC path to ground, then the additional load resistors may not be necessary. If needed, such load resistors are typically a high value, but a value dependent upon the application requirements.
- Note 3: To minimize pops and clicks, large polarized output capacitors should be a low leakage type.
- Note 4: Depending on the microphone device and PGA gain settings, common mode rejection can be improved by choosing the resistors on each node of the mSicrophone such that the impedance presented to any noise on either microphone wire is equal.
- Note 5: R3-R11 values depend on PBC; The low pass filters cutoff frequency range for Pin12-pin15 is from 8MHz to 33MHz.

## 18. PACKAGE SPECIFICATION



ITEM NAME	SYMBOL	MIN	NOM	MAX	
TOTAL THINCKNESS	A	0.8	0.85	0.9	
STAND OFF	A1	0	0.035	0.05	
MOLD THINCKNESS	A2	---	0.65	0.67	
L/F THICKNESS	A3	.203 REF			
LEAD WIDTH	b	0.2	0.25	0.3	
BODY SIZE	X	D	4 BSC		
	Y	E	4 BSC		
LEAD SIZE	e	0.5 BSC			
EP SIZE	X	J	2.4	2.5	2.55
	Y	K	2.4	2.5	2.55
LEAD LENGTH	L	0.35	0.4	0.45	



## 19. ORDERING INFORMATION

Part Number	Dimension	Package	Package Material
NAU88C14YG	4x4 mm	QFN-24	Green

NAU88C14

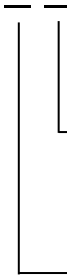

**Package Material:**

**G = Green Package (Halogen-free, RoHS-compliant) & TSCA-compliant**

**Package Type:**

**Y = QFN-24**

## 20. REVISION HISTORY

REVISION	DATE	DESCRIPTION
1.0	Dec 2009	Initial Release
1.1	Dec 2009	Note Added Electrical Specification table format updated
1.2	Jan 2010	SPI interface description updated Table 35 updated Package description updated
1.3	Jan 2010	Control interface description updated
1.4	Jan 2010	Package description updated
1.5	Feb 2010	Figure 7 updated
1.6	Mar 2010	Speaker THD for 2-stage updated Bit-8 of register 0x46 deleted from the document. Default value of register 0x47 updated
1.7	Apr 2010	Block diagram updated Table 25 was updated Table 34 was updated Register 0x41 Reserved updated
1.8	Nov 2010	Extended variable sample rate range
1.9	Jan 2011	Removed trailing clock cycle from SPI timing diagram Corrected Register 0x38 Register name Improved description of Mic Bias set up Added TMCLKH and TMCLKL parameters to table
2.0	Oct 2013	Corrected 2 wire timing diagram Figure 41 Added conditions $VDDA \geq DBVDD$ and $DBVDD \geq DBVDDC$ Corrected Digital I/O voltages to DBVDD from DCVDD.
2.1	Jan 2014	An additional remark of VDDSPK boost mode Modify Figure 27 Byte Write Sequence Modify Figure 28 2-Wire Read Sequence
2.2	Mar 2014	Corrected headphone full scale output Corrected rising/falling time specification of I2S

2.3	Jan 2015	Corrected T <sub>SDIOS</sub> setup time
2.4	Jul 2015	Changed 3.7KHz to 3.7Hz
2.5	Jul 2015	Changed EP size (MIN and NOM)
2.6	Jun 2016	Revise equation from * to / Silicon Revision ID
2.7	Mar 2016	Add important notice
2.8	Feb 2018	Remove 0x3[5] Remove 0x7[9] Change ALC description Add damping resistors on typical application diagram
2.9	Jun 2018	Change ALC description Add I2C low pass filter
3.0	Jun 2019	Add explanation for VDDSPK when SPKBST=0
3.1	Sep 13, 2022	Update junction temperature information
3.2	Nov 7, 2022	Update Figure 53 application diagram
3.3	Feb 1, 2023	Update Halogen-free, RoHS-compliant and TSCA-compliant description
3.4	Oct 30, 2023	Update T <sub>DOD</sub> description

## IMPORTANT NOTICE

Nuvoton Products are neither intended nor warranted for usage in systems or equipment, any malfunction or failure of which may cause loss of human life, bodily injury or severe property damage. Such applications are deemed, "Insecure Usage".

Insecure usage includes, but is not limited to: equipment for surgical implementation, atomic energy control instruments, airplane or spaceship instruments, the control or operation of dynamic, brake or safety systems designed for vehicular use, traffic signal instruments, all types of safety devices, and other applications intended to support or sustain life.

All Insecure Usage shall be made at customer's risk, and in the event that third parties lay claims to Nuvoton as a result of customer's Insecure Usage, customer shall indemnify the damages and liabilities thus incurred by Nuvoton.

---

*Please note that all data and specifications are subject to change without notice.  
All the trademarks of products and companies mentioned in this datasheet belong to their respective owners.*