

8 ~ 24 I/O EXPANDER WITH 256-LEVEL PWM OUTPUT**N55Pxxx
Data Sheet**

The information described in this document is the exclusive intellectual property of Nuvoton Technology Corporation and shall not be reproduced without permission from Nuvoton.

Nuvoton is providing this document only for reference purposes of Peripheral based system design. Nuvoton assumes no responsibility for errors or omissions.

All data and specifications are subject to change without notice.

For additional information or questions, please contact: Nuvoton Technology Corporation.

www.nuvoton.com

Table of Contents

1. GENERAL DESCRIPTION..... 3

2. FEATURES 3

3. PAD DESCRIPTION 5

4. BLOCK DIAGRAM..... 6

5. ELECTRICAL CHARACTERISTICS..... 7

 5.1 Absolute Maximum Ratings..... 7

 5.2 DC Characteristics 7

 5.3 AC Characteristics 8

6. REFERENCE APPLICATION CIRCUIT 10

7. PACKAGE INFORMATION 12

8. ORDERING INFORMATION..... 17

9. REVISION HISTORY 18

1. General Description

The N55Pxxx series is a general purpose programmable I/O device usable with different microprocessors through SPI interface. The N55Pxxx contains up to three 8-bit ports (BPA, BPB and BPC). There are 8~24 I/O pins which may be individually programmed for 6 separate command groups. The N55Pxxx features logical operating capability AND/OR/XOR for each bit of internal configuration register to speed up access. These GPIO pads can drive LED directly with 256 levels of brightness.

The N55Pxxx series contains following bodies with different GPIO pins:

Part No.	GPIO	I/O port
N55P082	8 pads	BPB
N55P162	16 pads	BPA, BPB
N55P242	24 pads	BPA, BPB, BPC

2. Features

- Wide range of operating voltage:
 - 2.0 ~ 5.5V
- SPI interface in mode 0
 - 4 SPI pins for communication
 - CSB as chip select pin (low active)
 - SCK for data synchronization (up to 8MHz)
 - MOSI for N55Pxxx to receive commands and data
 - MISO for the microcontroller to receive data
- 1 wakeup pad for the microcontroller
- 8~24 I/O pads
 - Bi-directional I/O pads
 - N55P082: 8 I/O pads
 - N55P162: 16 I/O pads
 - N55P242: 24 I/O pads
 - Status of each pad is independently controlled
 - Input
 - Floating
 - Pull high
 - Pull low
 - Dynamic pull low

- Dynamic pull high
- Output
 - CMOS high/low
 - Inverted CMOS high/low
 - Inverted open-drain NMOS output
 - Open-drain PMOS output
 - Constant sink current output
- Any pad can be selected for wakeup to work
- Speed up (AND/OR/XOR) groups to minimize load of MCU
- PWM I/O
 - 256 levels output
 - Internal ring oscillator @ 8 MHz
 - 4 clock sources
- Reset management
 - Power-on reset
 - S/W reset
- Standby current <1uA
- Connection of up to 2 N55Pxxx devices

3. Pad Description

Pad Name	Type	Power Supply	Description
BPA0 ~ BPA7	IO	VDDIOA	General-purpose IO, BPA port.
BPB0 ~ BPB7	IO	VDDIOB	General-purpose IO, BPB port.
BPC0 ~ BPC7	IO	VDDIOC	General-purpose IO, BPC port.
RJPA	I	VDDIOA	RJPA is connected to an external resistor to set the constant current of BPA port. It can be NC if constant current is not enabled.
RJPB	I	VDDIOB	RJPB is connected to an external resistor to set the constant current of BPB port. It can be NC if constant current is not enabled.
RJPC	I	VDDIOC	RJPC is connected to an external resistor to set the constant current of BPC port. It can be NC if constant current is not enabled.
CSB	I	VDDSPI	SPI chip select (low active)
SCK	I	VDDSPI	SPI clock
MOSI	I	VDDSPI	SPI data input
MISO	O	VDDSPI	SPI data output (clock output if TEST bit is "1")
DEVICE	I	VDDSPI	Device ID (floating)
WAKEUP	O	VDDSPI	Host wakeup
VDD	P		Positive power supply for core logic
VDDSPI	P		Positive power supply for SPI pads
VSS	P		Negative power supply for core logic and SPI pads
VDDIOA	P		Positive power supply for BPA port
VSSIOA	P		Negative power supply for BPA port
VDDIOB	P		Positive power supply for BPB port
VSSIOB	P		Negative power supply for BPB port
VDDIOC	P		Positive power supply for BPC port
VSSIOC	P		Negative power supply for BPC port

4. Block Diagram

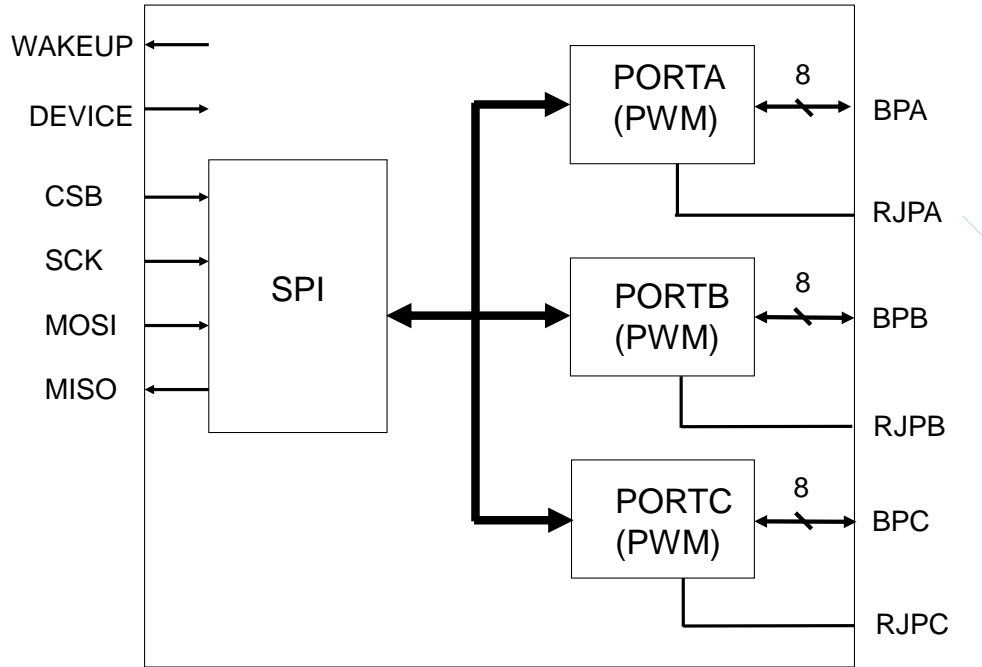

5. Electrical Characteristics

5.1 Absolute Maximum Ratings

Parameter	Symbol	Conditions	Rated Value	Unit
Power Supply	VDD-VSS	-	-0.3 to +7.0	V
Input Voltage	VIN	All Inputs	VSS -0.3 to VDD +0.3	V
Storage Temp.	TSTG	-	-55 to +150	°C
Operating Temp.	TOPR	-	0 to +70	°C
Total Max. IO Current	IM	-	-200/200	mA

Note: Exposure to conditions beyond those listed under the Absolute Maximum Ratings table may adversely affect the life and reliability of the device.

5.2 DC Characteristics

(VDD – VSS = 4.5V, TA = 25° C, No Load unless otherwise specified)

Parameter	Sym.	Conditions	Min.	Typ.	Max.	Unit
Operating Voltage	V _{DD}		2.0	-	5.5	V
Operating Current	I _{OP1}	V _{DD} =5.5V, CLK @8MHz	-		800	μA
Standby Current (STOP)	I _{DD1}	V _{DD} =5.5V, CSB=V _{DD}	-	-	1	μA
Input Low Voltage	V _{IL}	V _{DD} =4.5V	V _{SS}	-	0.3 V _{DD}	V
Input High Voltage	V _{IH}	V _{DD} =4.5V	0.7 V _{DD}	-	V _{DD}	V
Input Pull-High Resistor	RPH	VDD=3.0V	360	450	540	KΩ
Input Pull-Low Resistor	RPL	VDD=3.0V	360	450	540	KΩ
Output Current	I _{OL}	V _{DD} = 3V, V _{OUT} = 0.4V	8	-	-	mA
	I _{OH}	V _{DD} = 3V, V _{OUT} = 2.6V	-4	-	-	mA
Constant Output Low Current	I _{OLC}	V _{OUT} = 1.0V, RJPx = 82KΩ	14	20	26	mA
		V _{OUT} = 1.0V, RJPx = 220KΩ	7	10	13	
Constant Current Dev. by Voltage Drop	ΔI/I	V _{DD} = 2.6~4.5V RJPx = 82KΩ [I(4.5V)-I(2.6V)] / I(4.5V)		10	15	%

5.3 AC Characteristics

($V_{DD} - V_{SS} = 3.0V$, $T_A = 25^{\circ}C$; unless otherwise specified)

Parameter	Sym.	Conditions	Min.	Typ.	Max.	Unit
SCK Clock Frequency	f_{CLK}		-	-	8	MHz
Input Rise Time	t_R		-	-	5	nS
Input Fall Time	t_F		-	-	5	nS
SCK High Time	t_{WH}		58	-	-	nS
SCK Low Time	t_{WL}		58	-	-	nS
CSB High Time	t_{CS}		100	-	-	nS
CSB Setup Time	t_{CSS}		50	-	-	nS
CSB Hold Time	t_{CSH}		50	-	-	nS
Data in Setup Time	t_{SU}		5	-	-	nS
Data in Hold Time	t_H		5	-	-	nS
Output Valid Time	t_V		-	-	50	nS
Output Hold Time	t_{HO}		0	-	-	nS
Output Disable Time	t_{DIS}		-	-	100	nS
Output Disable Time	t_{DIS}		-	-	100	nS

SPI Timing

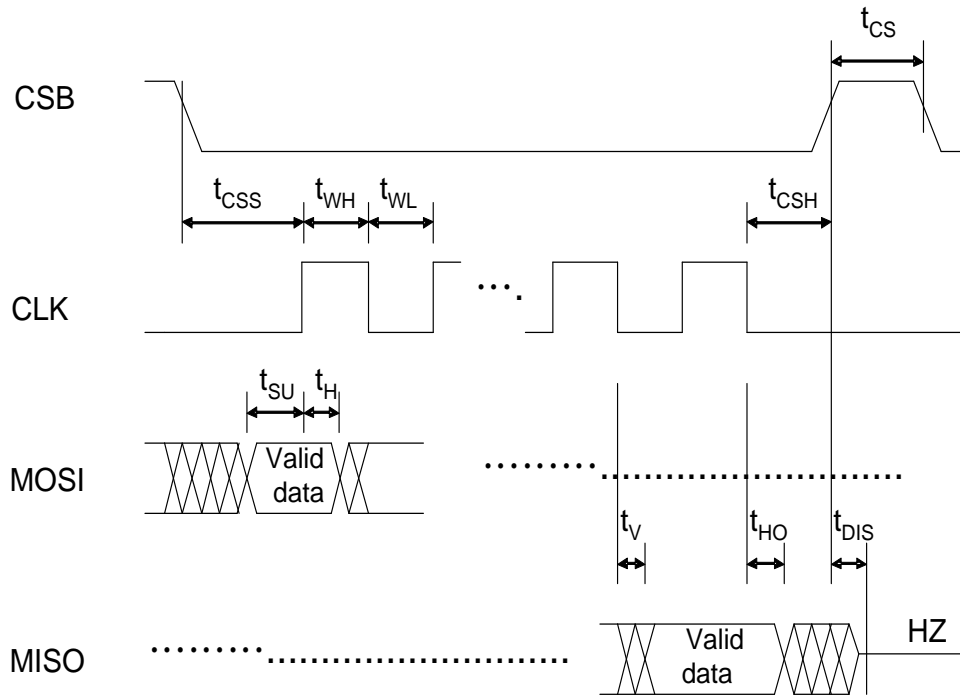

6. Reference Application Circuit

Disable Constant Current

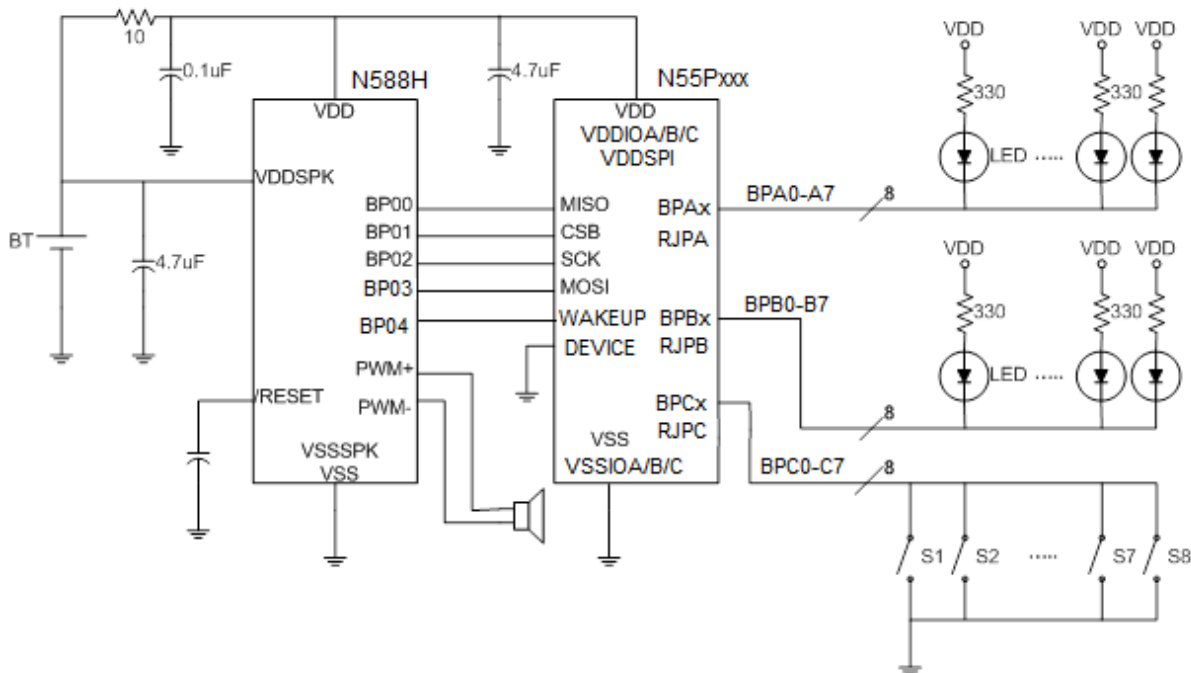

Enable Constant Current

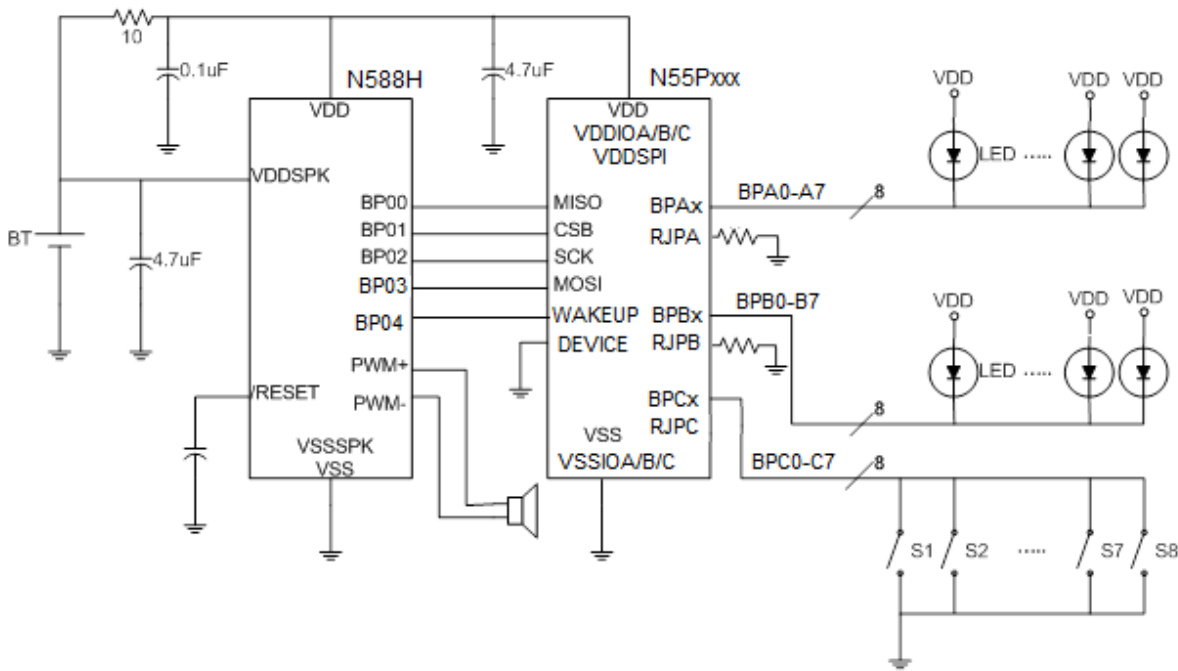

2 x N55Pxxx Cascade

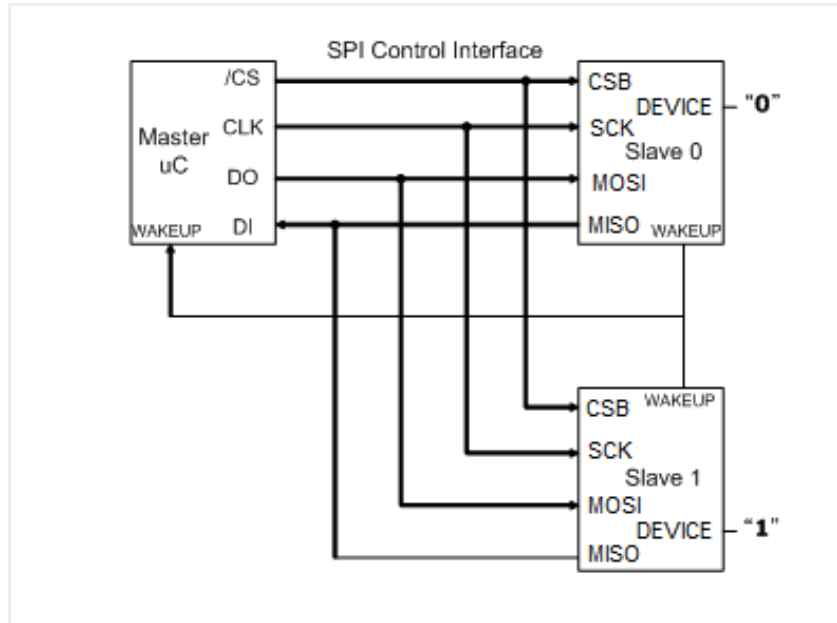

7. Package Information

N55P242 Package Pin Assignment (LQFP48)

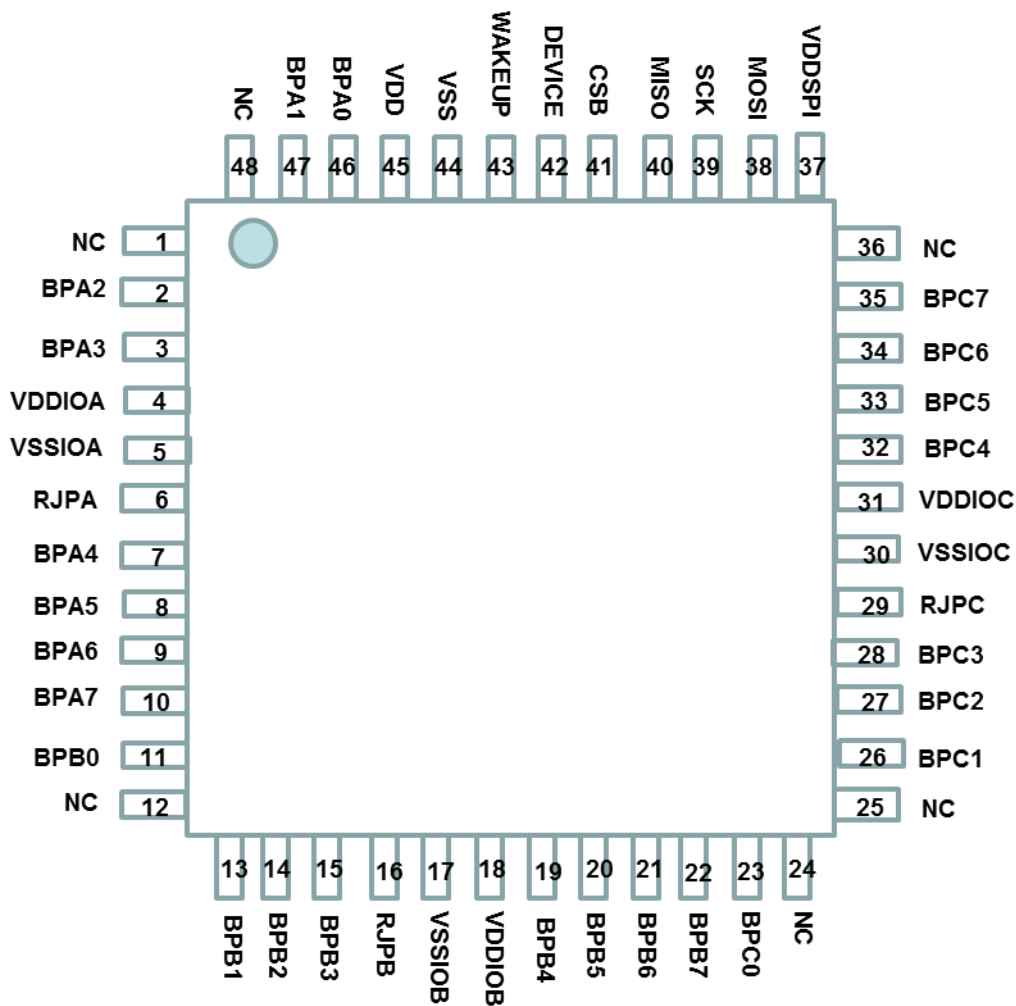

N55P242 Package Dimension (LQFP48)

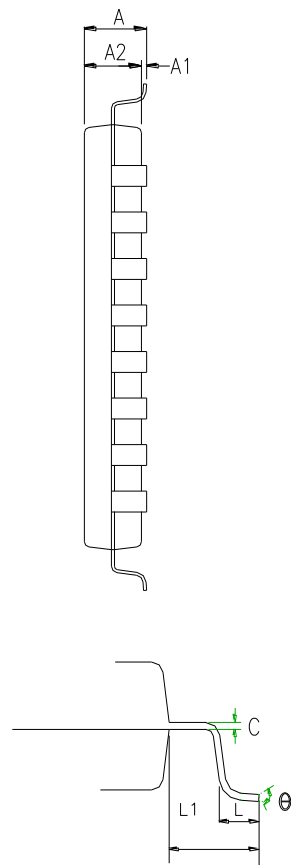
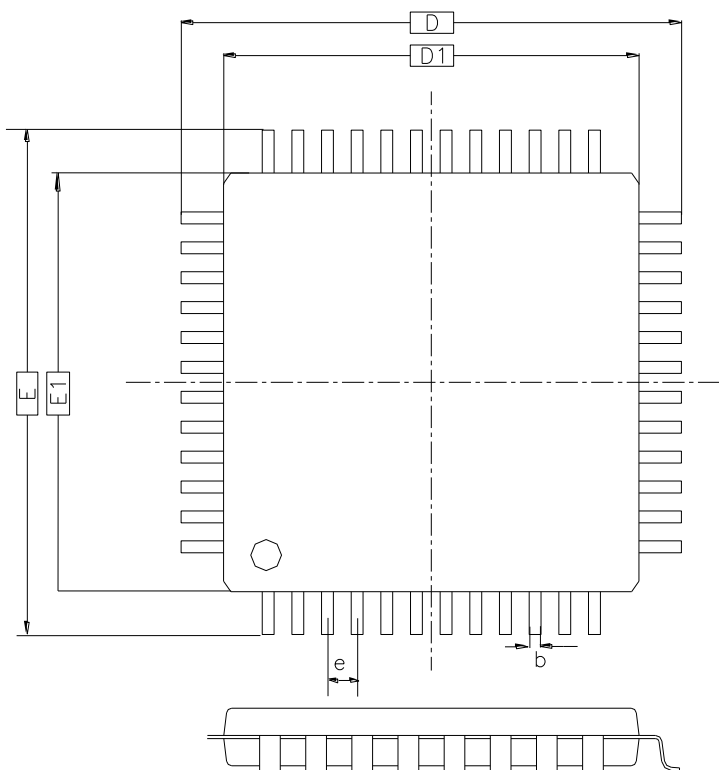

COTROL DIMENSIONS ARE IN MILLIMETERS.

SYMBOL	MILLIMETER			INCH		
	MIN.	NOM.	MAX.	MIN.	NOM.	MAX.
A	—	—	1.60	—	—	0.063
A1	0.05	0.10	0.15	0.002	0.004	0.006
A2	1.35	1.40	1.45	0.053	0.055	0.057
D1	6.90	7.00	7.10	0.272	0.276	0.280
E1	6.90	7.00	7.10	0.272	0.276	0.280
e	0.35	0.50	0.65	0.014	0.020	0.026
D	8.9	9.00	9.10	0.350	0.354	0.358
E	8.9	9.00	9.10	0.350	0.354	0.358
L	0.45	0.60	0.75	0.018	0.024	0.030
L1	—	1.00	—	—	0.039	—
C	0.09	—	0.20	0.004	—	0.0079
θ	0°	—	7°	0°	—	7°
b	0.17	0.22	0.27	0.007	0.0087	0.011

N55P162 Package Pin Assignment (QFN32)

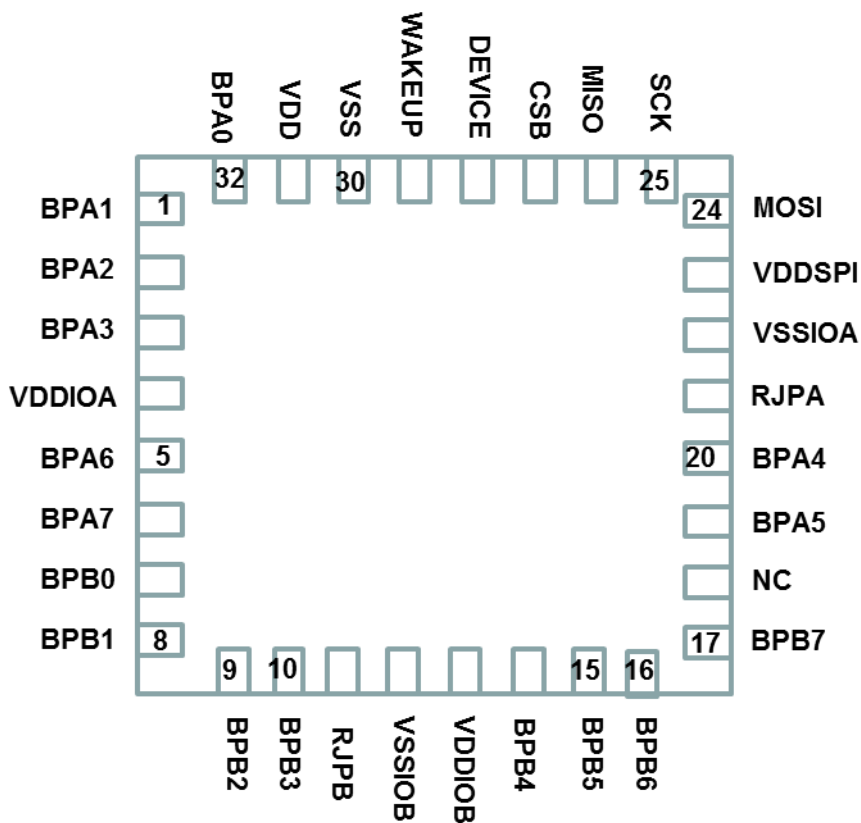

N55P082 Package Pin Assignment (QFN32)

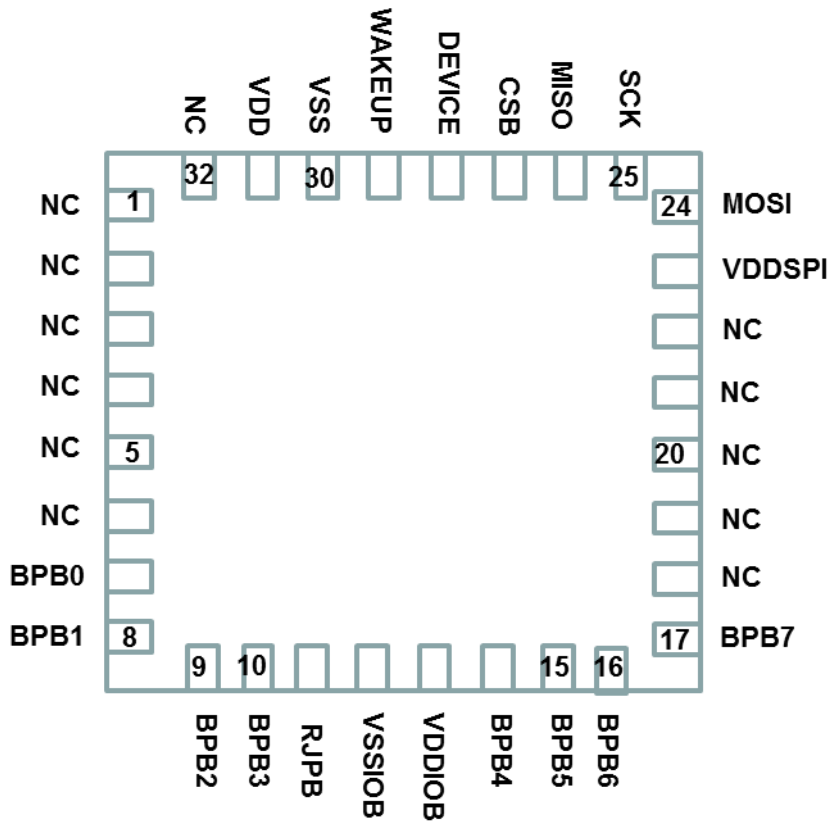

N55P082, N55P162 Package Dimension (QFN32)

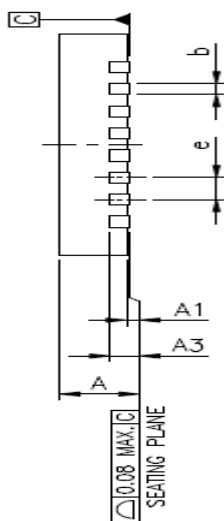
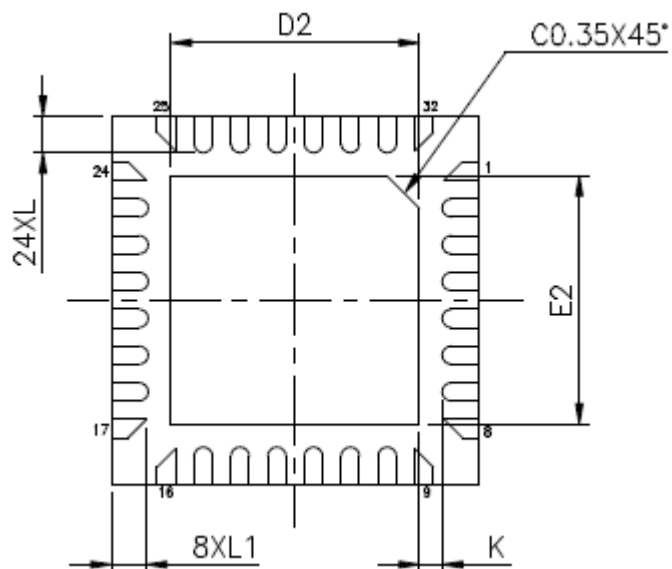
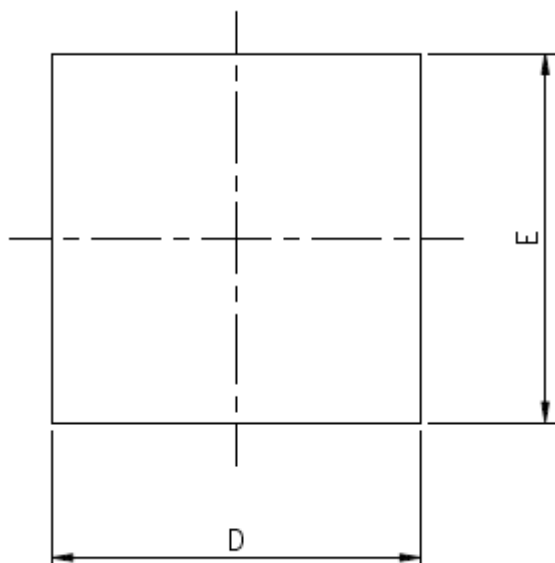

	Symbol	Min	Nom	Max
Total Thickness	A	0.7	0.75	0.8
Stand Off	A1	0.0	0.02	0.05
L/F Thickness	A3	0.2 REF.		
Lead Width	b	0.15	0.20	0.25
Body Size	D	4.00 BSC		
	E	4.00 BSC		
Lead Pitch	e	0.40 BSC		
Lead Length	L	0.35	0.4	0.45
	K	0.2	--	--

Symbol	L/F SIZE	Dimension in mm		
		MIN.	NOR.	MAX.
D2	114X114 mm	2.6	2.7	2.75
E2		2.6	2.7	2.75

8. Ordering Information

Part No.	Shape	Type	Remark
N55P242	H	Die Form	24 I/O
N55P242L48	E	Package Form, LQFP48 (7 x 7 mm)	24 I/O
N55P162	H	Die Form	16 I/O
N55P162N32	E	Package Form, QFN32 (4 x 4 mm)	16 I/O
N55P082	H	Die Form	8 I/O
N55P082N32	E	Package Form, QFN32 (4 x 4 mm)	8 I/O

9. Revision History

Version	Date	Substantial Changes	Page
A1.0	Oct. 2016	Initial Release	All
A2.0	Jan. 2017	Revise SCK Clock Frequency AC spec Add Package Information	8 12~16
A2.1	Mar. 2017	Update Constant current deviation DC spec	7

Important Notice

Nuvoton Products are neither intended nor warranted for usage in systems or equipment, any malfunction or failure of which may cause loss of human life, bodily injury or severe property damage. Such applications are deemed, "Insecure Usage".

Insecure usage includes, but is not limited to: equipment for surgical implementation, atomic energy control instruments, airplane or spaceship instruments, the control or operation of dynamic, brake or safety systems designed for vehicular use, traffic signal instruments, all types of safety devices, and other applications intended to support or sustain life.

All Insecure Usage shall be made at customer's risk, and in the event that third parties lay claims to Nuvoton as a result of customer's Insecure Usage, customer shall indemnify the damages and liabilities thus incurred by Nuvoton.

*Please note that all data and specifications are subject to change without notice.
All the trademarks of products and companies mentioned in this datasheet belong to their respective owners.*